

SPECIFYING GUIDE

Lifestyle Affinity USA

ED355003



Terry Lifts
◆ THE ONE TO TRUST ◆



CONTENTS

01 - Specifications

- 01 Introduction
- 01 End-user / Client and Environmental Considerations
- 02 Hydraulic drive system
- 02 Standard features
- 02 Compliance
- 03 Available options
- 04 Site Considerations
- 05 Weights (ISPM15) for shipping
- 06 Electrical Schematic
- 07 Dimensions
- 08 Minimum Headroom Requirements
- 09 Guides

02 - Loadings

- 10 Loading Details

03 - Aperture Details

- 11 Aperture in Floor Joists
- 12 Example Double Joist Details
- 13 Upper Level Finish Floor
- 13 Aperture Protection
- 14 Installation in Concrete Floor
- 14 Aperture Frame

04 - Guide Fixing

- 15 Upper Guide Ceiling Fix
- 16 Wall Fix - Alternate method where ceiling fix is not possible

05 - Guide Fixing for Travel Over 118”

- 17 Intermediate Guides
- 18 Downstairs Wall Patch
- 19 Lower Guide Brace Kit

06 - Skirting Board, Coving and Infill

- 20 Skirting and Coving Considerations
- 20 Infill

07 - Controls

- 21 Control Details

08 - Flush Mount Call Station Specification

- 22 Brick / Solid Wall
- 22 Plasterboard Wall

09 - Affinity Check List

- 23 Spec Check List

10 - Site Check Form

- 25 Affinity Site Check Form - XE00027

Introduction

The Lifestyle Affinity is a through floor lift designed for a single standing/seated person, travelling between fixed floor levels in a domestic property with a maximum carrying capacity of 550 lbs (250 kg).

The Affinity functions without a traditional lift shaft and includes an automatic infill panel, ensuring safety by securing the aperture when parked at either level.

Emergency communication is available through a telephone provided within the car. Additionally, both the aperture infill and the car underpan feature half-hour fire-rated panels as a standard safety measure.

The lift car panels are constructed from powder-coated steel, offering easy cleaning using common household cleaners. Upholstery, made from high-quality materials, can be cleaned in the same manner.

End-user / Client and Environmental Considerations

Final lift selection should include full consultation with the client and/or their authorised representative. The following should be discussed and agreement obtained:

- Basic principles of lift operation and safety features.
- Location of lift and ease of access at lower and upper levels.
- Duty cycle (See Page 02 - Hydraulic Drive System).
- Check that the load capacity of 550 lbs (250 kg) will not be exceeded.
- Long term suitability of equipment and long term user mobility i.e. will client require/ change wheelchair or become incapable of operating existing controls?
- Location of lift powerpack.
- The extent of the intended preparatory work and the time period involved.
- Any deviation from the standard options listed in this specifier's guide must be approved by Terry Group Ltd.
- In the event of a change to client requirements or specification, a new completed survey and specification sheet and quotation would be required rather than modifications to current documents.
- Determine if Local Authority documents are required, e.g. Building Notices, and confirm who will be submitting them.

Hydraulic drive system

Exceptionally smooth and quiet operation by virtue of remote power unit.

Inherent safety system to guard against free fall of car.

Duty cycle - 10 cycles per hour with max load.

Flexibility of installation – minimal headroom required in first floor room and guides can be installed across windows or against non-load bearing walls.

Standard features

Designed and manufactured to BS5900:2012 as applicable. Exova Warrington Fire Research Centre assessment WF320926.

Glass panels - clear

Rear panel - painted

Handrail - powder coated steel

Car controls on handrail. Wireless control stations at both floors which include direction, stop, and door open/close controls. Upper and lower call station controls are in a white moulded casing.

Top cap - painted as per lift colour.

Interlinked smoke detectors. Fire protection behaviour to BS5900:2012 (required to comply).

Seat - Charcoal.

Carpet - Charcoal.

Standard telephone installed under seat.

In the event of power failure battery back up system allows operation of car in the down direction by normal controls with all safety systems in operation.

Standard colours, Lifts, Guides, Carriage, Aperture - White with blue panel, Grey with red panel, Black with silver panel.

The car is fitted with LED lighting with adjustable brightness and time delay which switches on when lift is called. By pressing and holding the stop and up buttons, the lights will automatically sequence through the different intensity levels. When the desired level is reached, release both buttons.

Compliance

The Lifestyle Affinity homelift has been designed for use in a domestic environment in compliance with the following Directives:

| | |
|--|--|
| 2004/108/EEC 2006/42/EC | Electromagnetic Compatibility Directive Machinery Directive |
|--|--|

This lift also fulfils all the relevant provisions of the following Standards:

| | |
|------------------------|---|
| BSEN 12015:2014 | Electromagnetic compatibility. Product family standard for lifts, escalators and moving walks. Emission |
| BSEN 12016:2013 | Electromagnetic compatibility. Product family standard for lifts, escalators and moving walks. Immunity |
| BS5900:2012 | Powered homelifts with partially enclosed carriers and no liftway enclosures. Specification |

Available options

Alternative RAL colours.

Additional receiver (concrete floors).

Flush mounted hard wired landing stations (See Page 21).

Isolate fob (See Page 21).

Hand-held remote control (See Page 21).

Black or white wall controls (membrane only, not flush mounted).

Customer supplies own flooring material. 1/8" max thickness.

Site Considerations

Lift Location and Suitability

Is the lift accessible by a person at the upper and the lower

Check the travel requirements against headroom available.

Is access route to the lift position suitable to deliver the lift components?

Do any doors, cupboards, or wardrobe doors open into lift area?

Does the door hand suit at both upper and lower level?

Where a lift is passing from a garage to a room within the dwelling then 30 minutes fire separation is required for integrity (passage of flame), insulation and load bearing capacity. In order to achieve these requirements a full enclosure at one level will be required, this will also enable the thermal requirements of the Building Regulations to be met.

If the user has a pacemaker fitted, they must not use the lift unless a special arrangement has been made.

Is seating required?

Will the lift restrict the everyday use of the room in any way?

Can furniture slot in around the lift? Furniture and other obstacles should not be positioned less than 4" away from moving parts of the lift.

A telephone must always be specified when the user is to operate the lift whilst home alone.

Powerpack Location

Is the powerpack location acceptable to all parties?

Will the powerpack location restrict access if fitted in passageway etc?

Powerpack can be located internally or externally. If internal, ensure location is suitable for access and noise containment.

Will powerpack be located adjacent to a neighbours property?

Is the hydraulic pipe run acceptable? (If surface mounted, advise client of where the trunking will be fitted). Note that the minimum bend radius of the hose is 3 1/2" and neat external corners are not possible.

Structural Considerations

Are both of the upper and lower floors level to within +/-3/8" measured over a running length of 60"?

Are the walls and lower floor strong enough to take the lift loadings?

Will the cutting of the aperture affect the integrity of the floor?

Are there any radiators/water or gas pipes adjacent to lift position? Any potential for pipe work fouling aperture?

Who is submitting the Building Notice to Building Control?

Are guide infill panels required at upper or lower level

Electrical Considerations

Is meter location clearly highlighted on site plan?

Is client aware of possible trunking run to lift power point position?

Do electrical or TV aerial sockets have to be repositioned or blanked off?

Are there any ceiling lights in the lift area that may foul the lift?

Does the house have old wiring and is it earth bonded?

Is there any wiring through the area where the aperture is to be formed?

Is a card or coin meter currently fitted?

At the intermediate level, is the floor concrete or is there a lot of metalwork or insulation? Is there anything else that may effect wireless call stations?

Installation Day Considerations

What is access like to the house (van parking and carrying lift parts)?

What are the walls like for drilling in to? Will the wall accept expansion or resin anchors?

Is there 2" clear around 3 sides of the formed aperture to skirting / coving etc. (e.g. no pipes and cables)

Are positions of wall stations clearly identified?

Is there an electrical supply for power tools?

Will there be other contractors on site?

Who is going to do the preparation work?

Will the user be available for the lift demonstration and hand over?

Weights (ISPM15) for shipping

| Component | Weight (lbs) |
|--------------------------|--------------|
| Aperture liners (each) | 13 |
| Plasterboard and Tacfire | 22 |
| Trapdoor panel | 55 |
| Carriage sides (each) | 88 |
| Carriage door | 66 |
| Carriage underpan | 22 |
| Power pack | 99 |
| Sling | 88 |
| Ram | 106 |
| LH lower guide | 44 |
| Control tube set | 31 |

Electrical Schematic

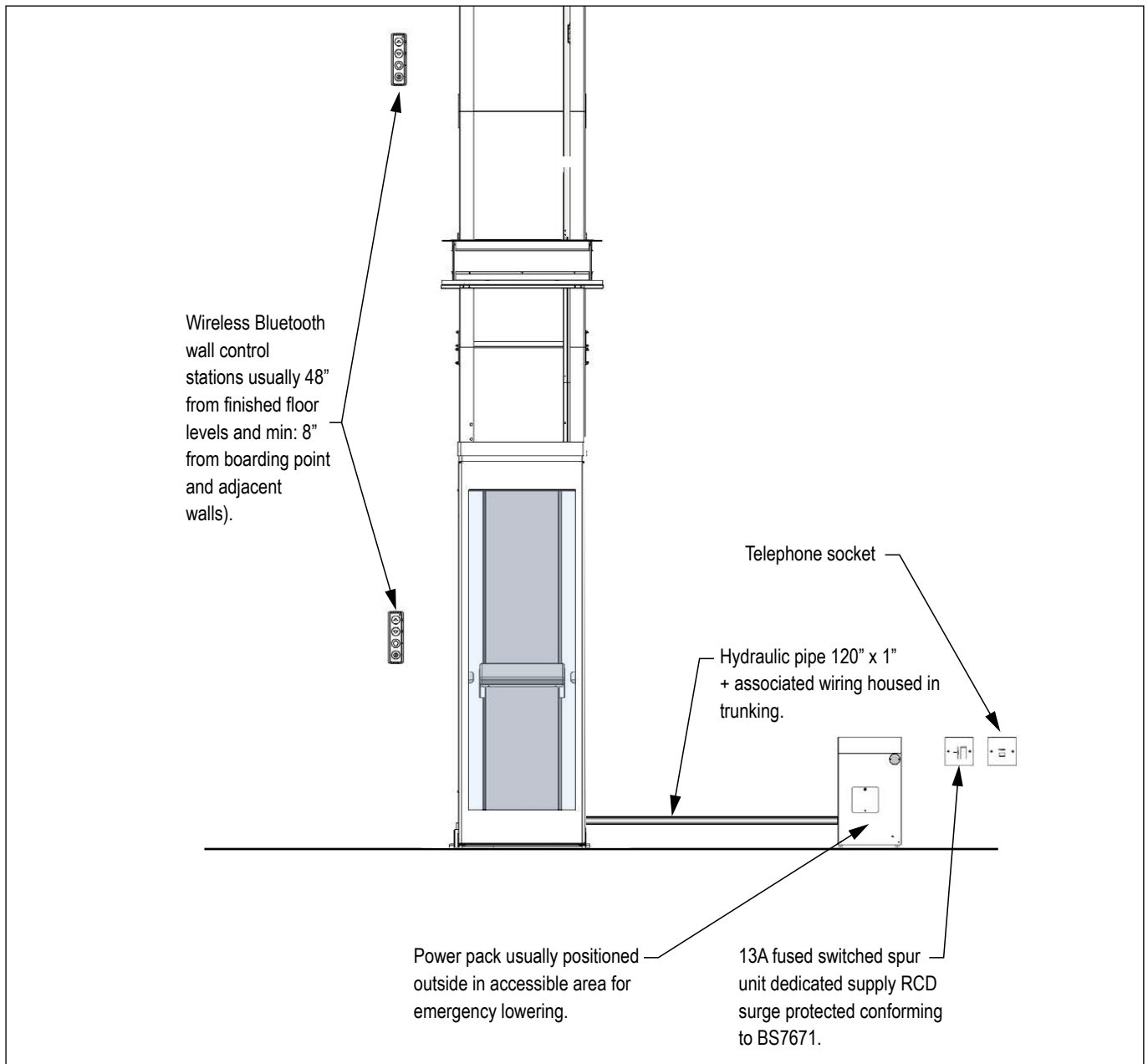

Notes:

- Supply a 240v single phase, dedicated power supply terminating at a 13-amp switched fused spur, type B16-amp MCB and protected by RCD with Surge Protection, to conform to current regulations. Positioned adjacent to the lift at the same level as the powerpack (motor) and in accordance with the survey drawing. To be accessible for switching when lift is positioned at the lower level.
- 1 x duct from the lower left hand guide position, 8" up off the ground. This goes back to the power pack. 2 1/2" duct if swept elbows / 1 3/4" duct if straight run. 1 x 3/4" duct from the spur to the power pack.
- Wifi units and even low energy light bulbs can affect the wireless call stations performance (it may be necessary to reposition routers / change bulbs). In addition non-standard floor constructions or finishes may effect the wireless performance e.g. concrete floors, foil backed insulation, under floor heating.
- Ducting can be solid plastic pipe or Flexi Hose.

Dimensions

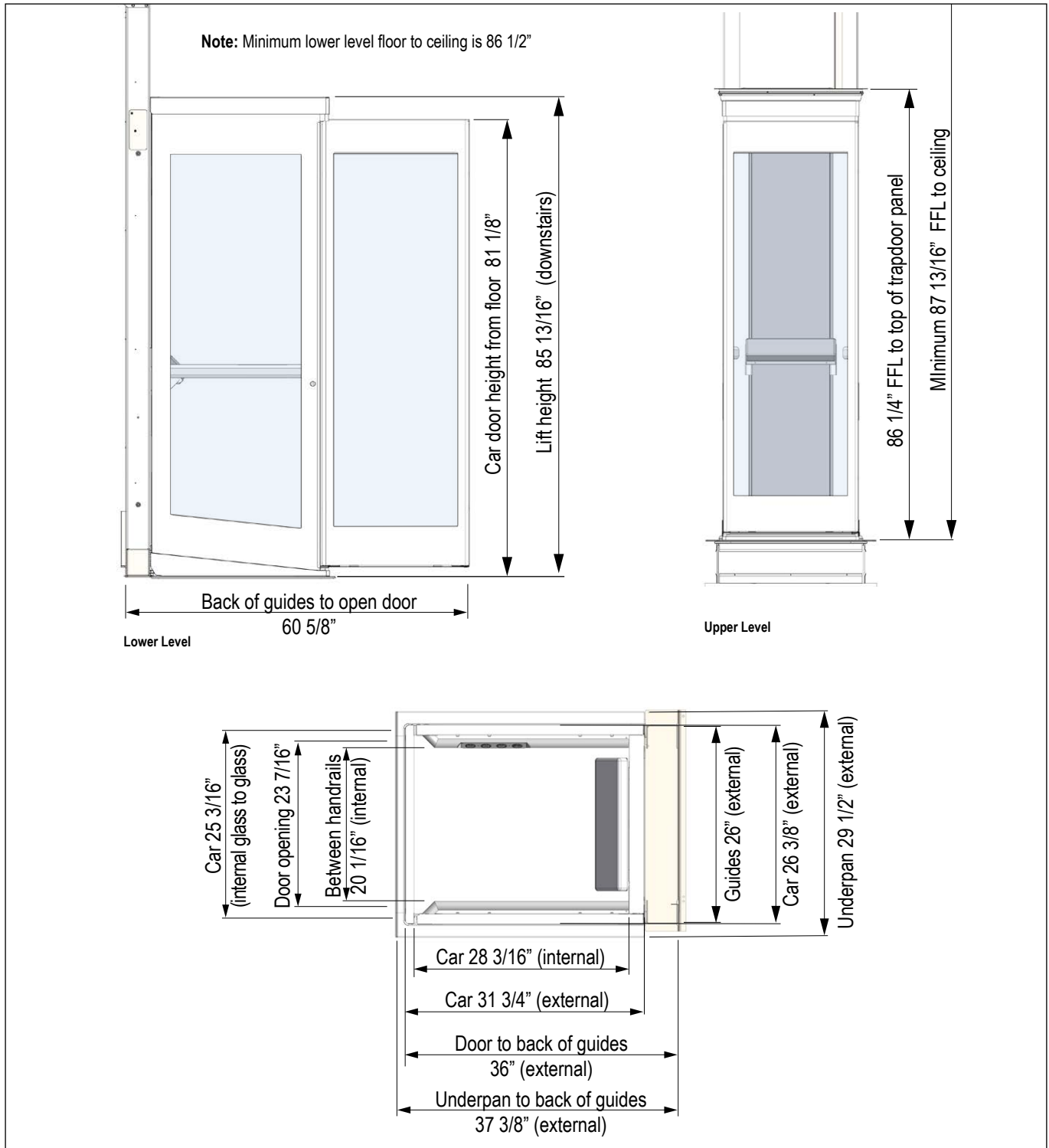

| Standard capacities / travel | |
|------------------------------|--|
| Capacity | Carriage - 550 lbs. (250 kg) Trapdoor - 550 lbs. (250 kg) Note: Maximum loor covering weight which can be applied to trapdoor 14 lbs. (6.35 kg) evenly distributed. |
| Travel | 141" |
| Speed | 2 3/8" per second |

Minimum Headroom Requirements

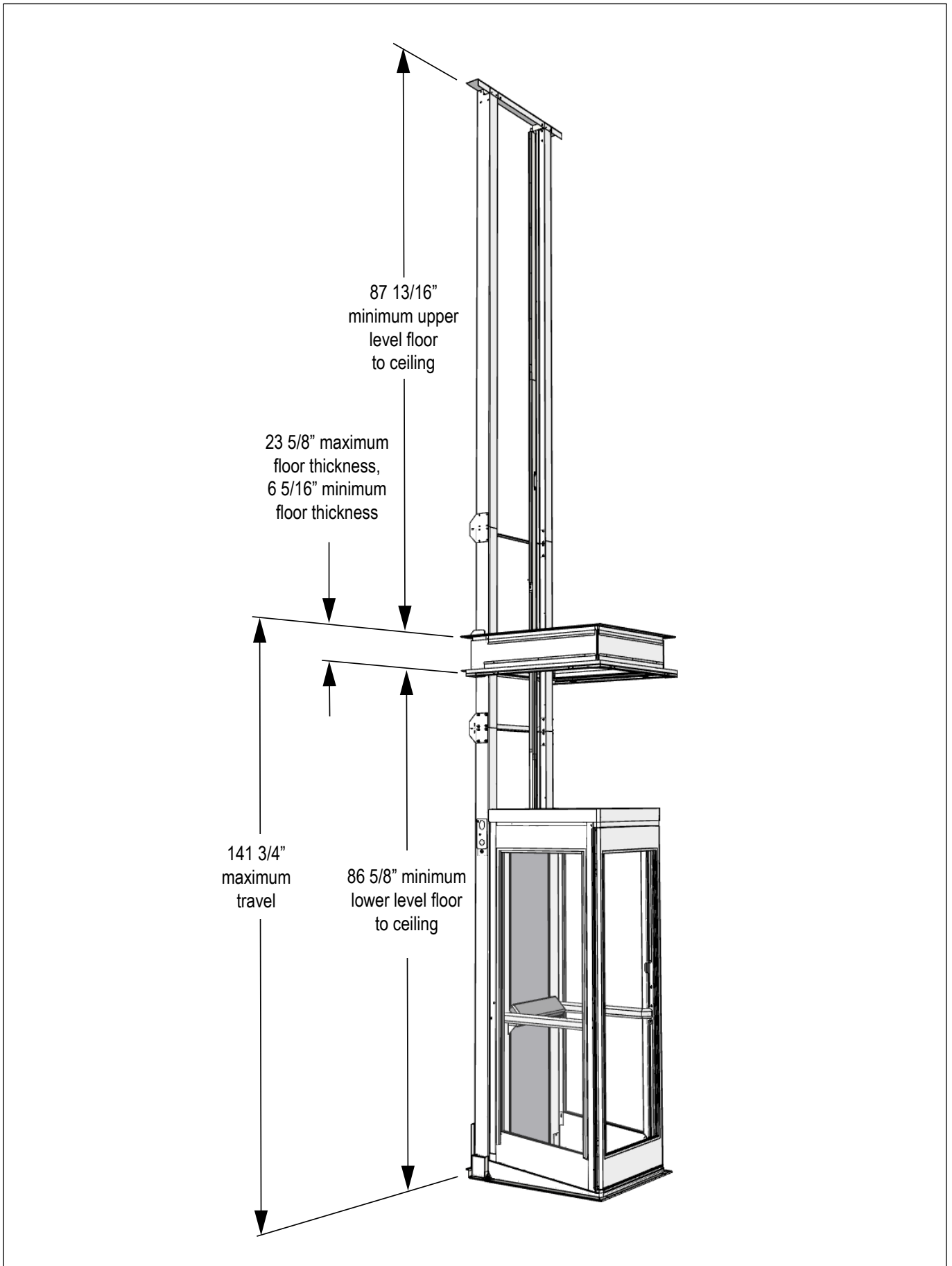

Guides

Up to and including 118" travel

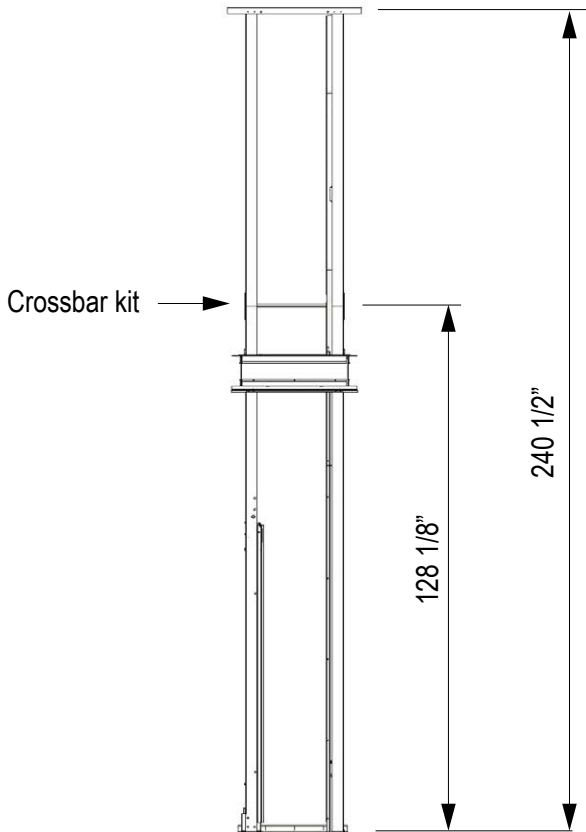

Over 118" travel

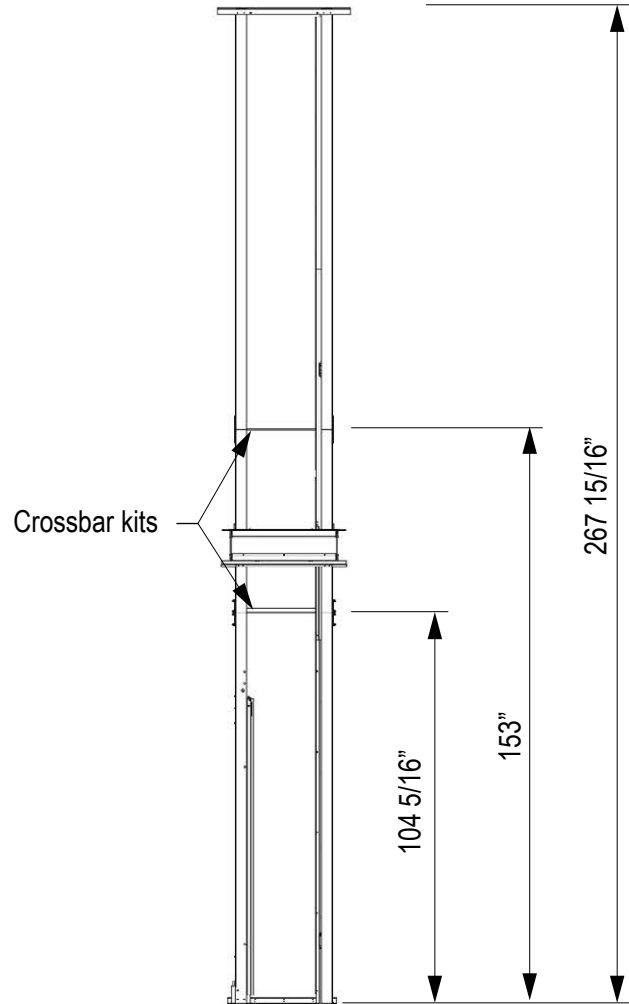

Note:

- If the lower level floor to ceiling is less than 84 5/8" then special guides will be required.
- If the actual overall height available exceeds the overall height of the guides (240 1/2") then a top guide extension piece (30" long) is required to extend the guides to the ceiling of the upper floor.



Note:

- If the lower level floor to ceiling is less than 110" then special guides will be required.
- If the actual overall height available exceeds the overall height of the guides (265") then a top guide extension piece (30" long) is required to extend the guides to the ceiling of the upper floor.

Loading Details

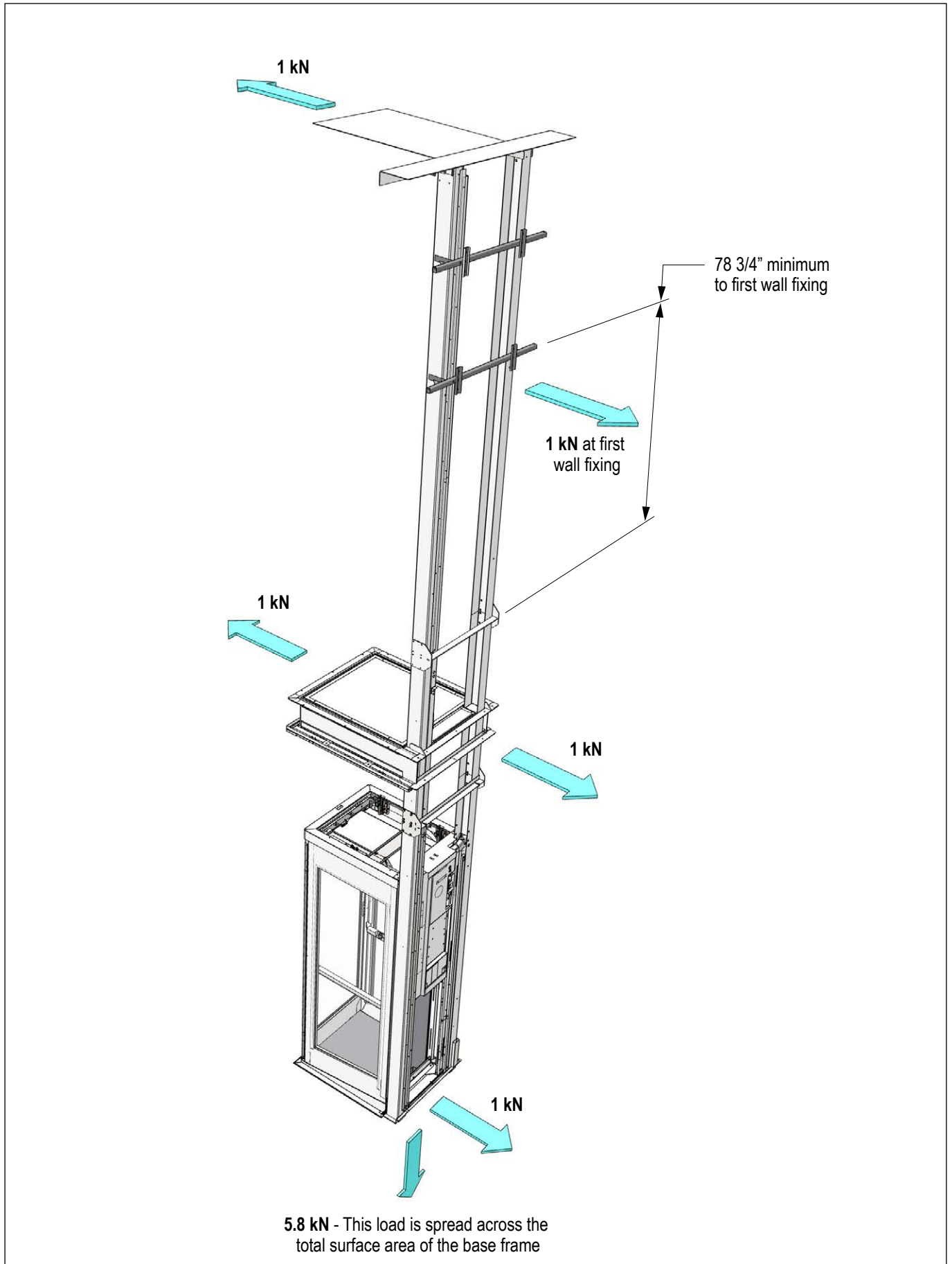

Aperture in Floor Joists

! Note:

- Ensure the upper floor is levelled perfectly. It is essential the aperture be formed level. Any deviation of aperture level will result in the aperture needing to be re-levelled.

- The rear wall joist must be installed at all times. It provides the main load bearing attachment support for the aperture.

- All joists to be fitted perfectly level in all planes. The top surface of the joists must be perfectly level and square.

- Minimum floor thickness is $6 \frac{5}{16}$ " and maximum $23 \frac{5}{8}$ ". Please specify a 'Deep Aperture ($13 \frac{13}{16}$ " - $23 \frac{5}{8}$ ")' where the aperture depth exceeds $13 \frac{13}{16}$ ".

- Joist ends should be trimmed onto other joist using proprietary joist hangers or built into structural walls by a min 4".

- To comply with Building Regulations all supporting and trimming joists will be double joists.

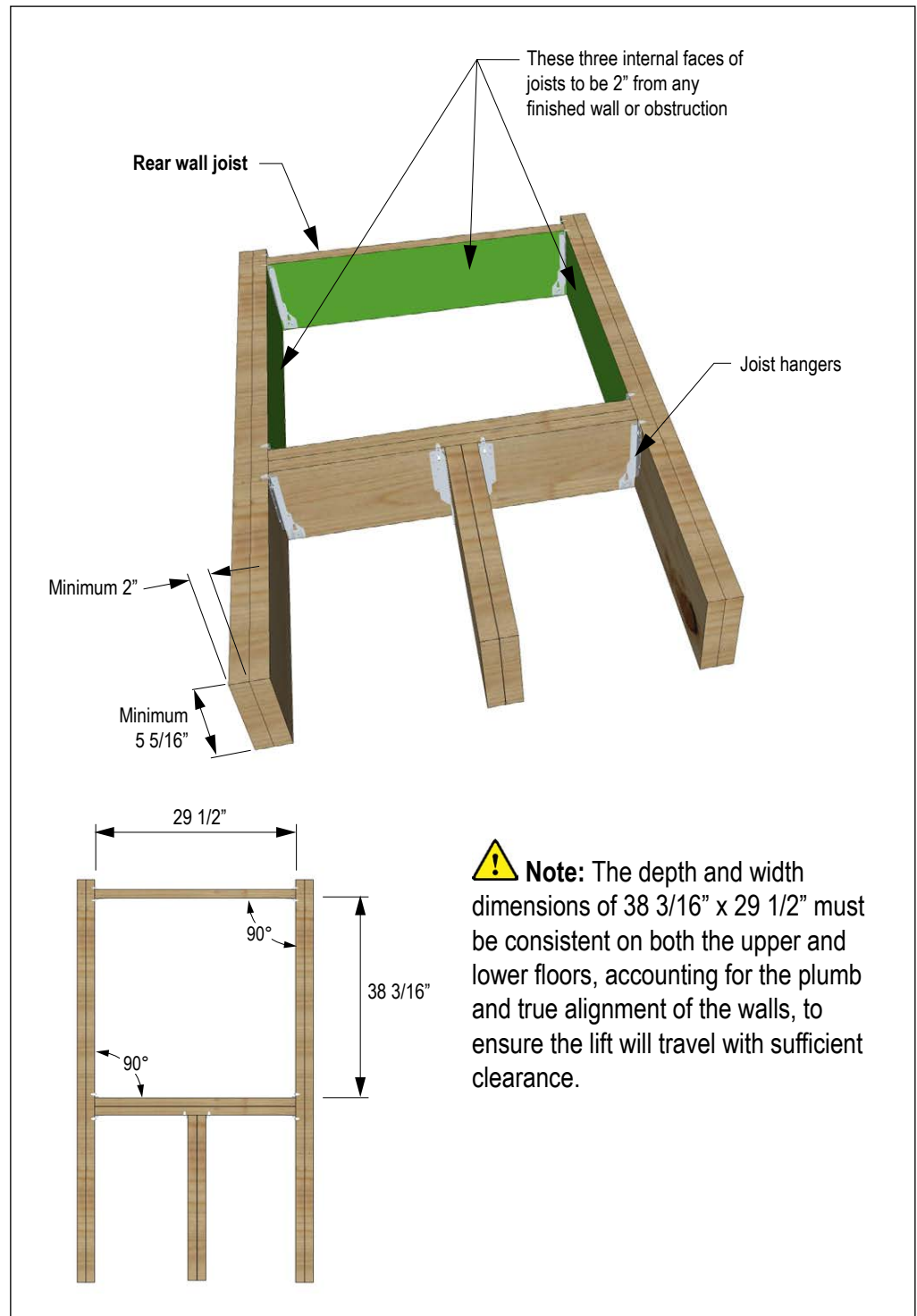

Example Double Joist Details

! Note:

- Refer to TRADA 4th Edition for calculation information.
- Building contractor to ensure Building Control Approval is obtained, wireless performance e.g. concrete floors, foil backed insulation, under floor heating.

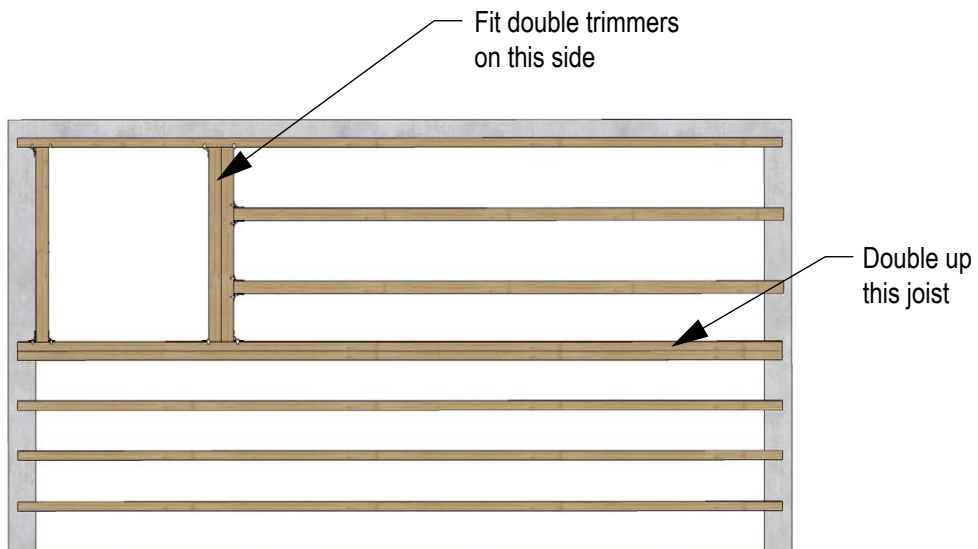

Fit an additional joist of the same size, onto the first full joist, i.e. double joist. This must be bolted to the original at max 12" centres for the full length as above, use M10 bolts.

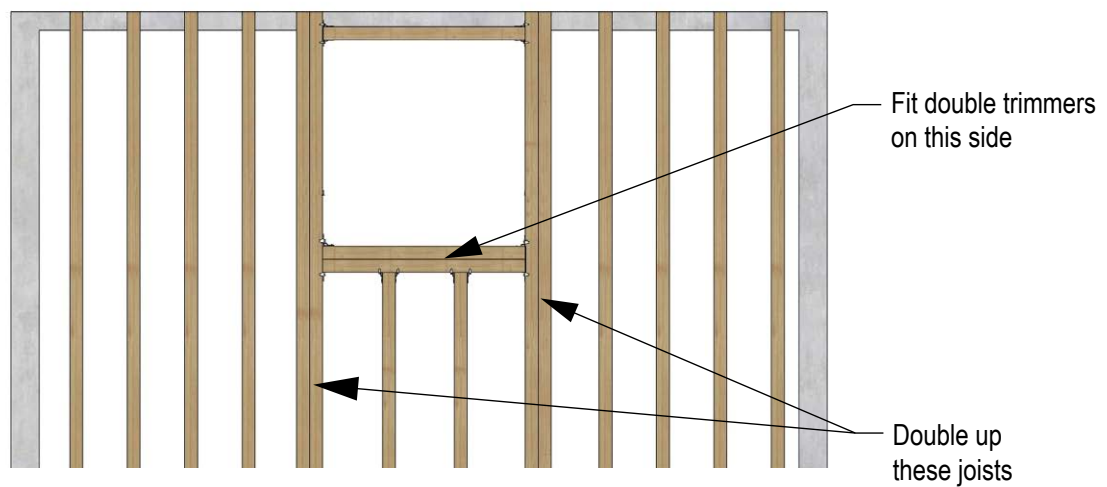

Upper Level Finish Floor

Upper level finish floor covering to be fitted flush to the inside faces of the four joists.

The same applies for the plasterboard and skim to the lower level ceiling.

Trapdoor can be covered with carpet (no wood flooring or tiles). Max load spread evenly over trapdoor of 14 lbs. (6.35 kg).

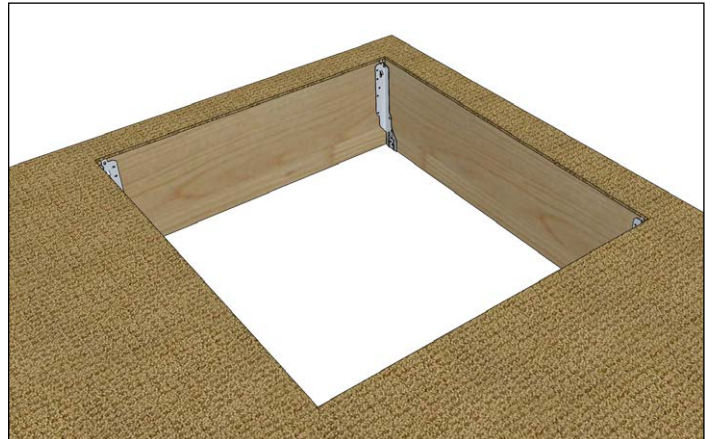

Aperture Protection

It is required that after an aperture has been prepared, the hole in the floor is covered. It is important that the upstairs floor remains flush. This is achieved by recessing a piece of 3/4" thick ply into the hole. The piece of ply should be fitted such that it has a 1/4" clearance around each of the sides.

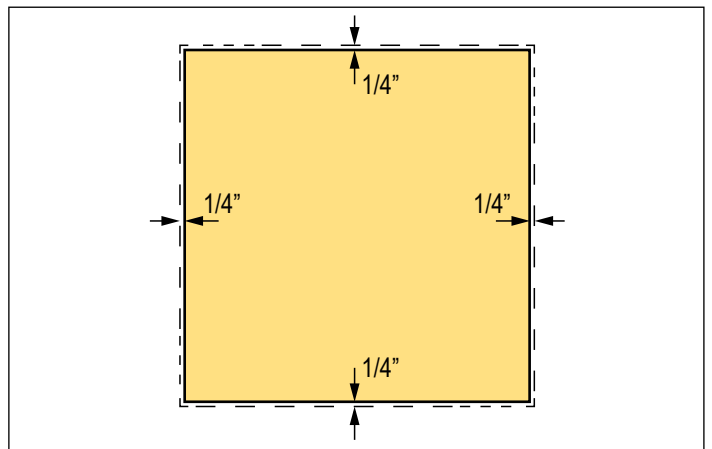

The ply is supported by a single joist fitted in the centre of the aperture across the greatest span and timber battens around the edges. The centre joist is recommended to be the same size as the rest of the joists in the aperture construction and the timber battens are to be a minimum of 2"x1".

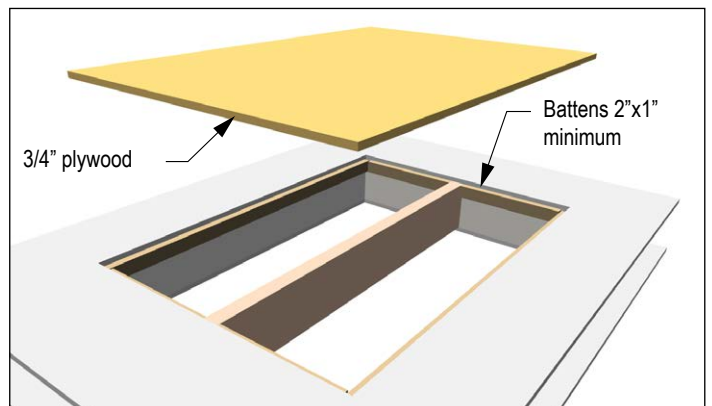

Installation in Concrete Floor

A timber frame needs to be inserted into the concrete floor.

When the lift is installed, the steel upper and lower aperture frames for the lift (not shown), will be fitted directly to the timber frame.

The supporting structure shown in the illustration is to support the timber frame while it is secured by pouring a suitable grouting from above.

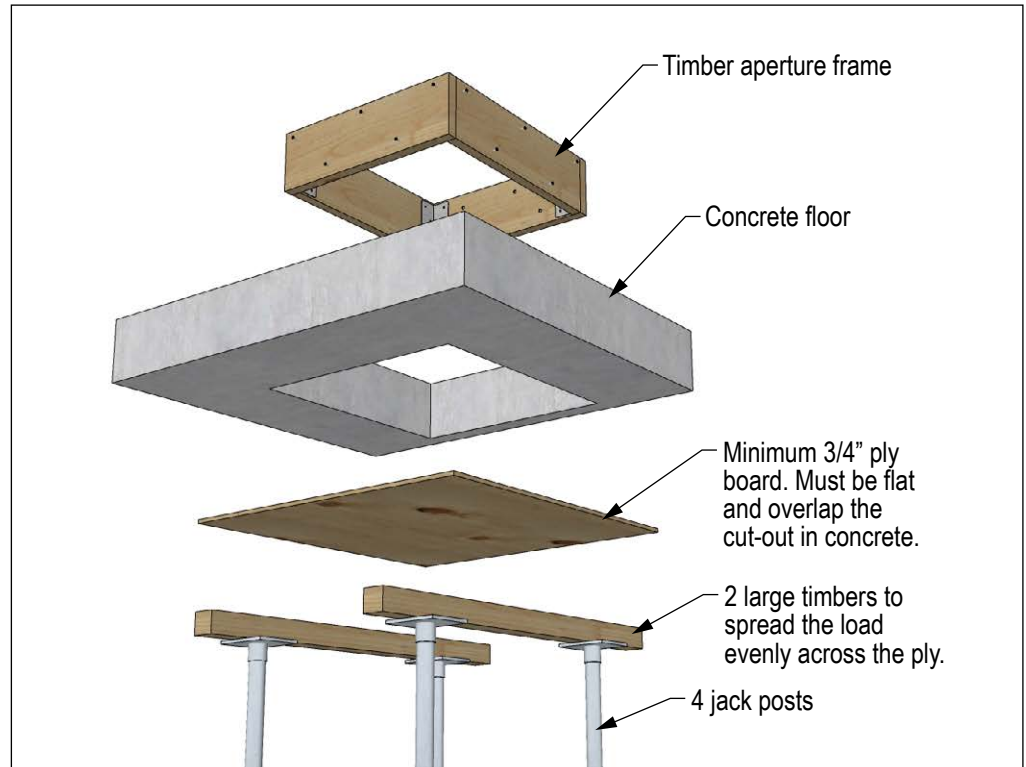

Aperture Frame

⚠ Important: The timber frame must be square and flat.

When grouting is fully cured, fix through the frame into the original concrete floor

Use M10 Rawl bolts (or similar) or M10 studding with chem-fix adhesive.

The fixings must be recessed (so the inside of the frame is flush).

A minimum of 16 fixings are required (minimum 4 each side).

The fixings must protrude into original concrete floor by a minimum of 3".

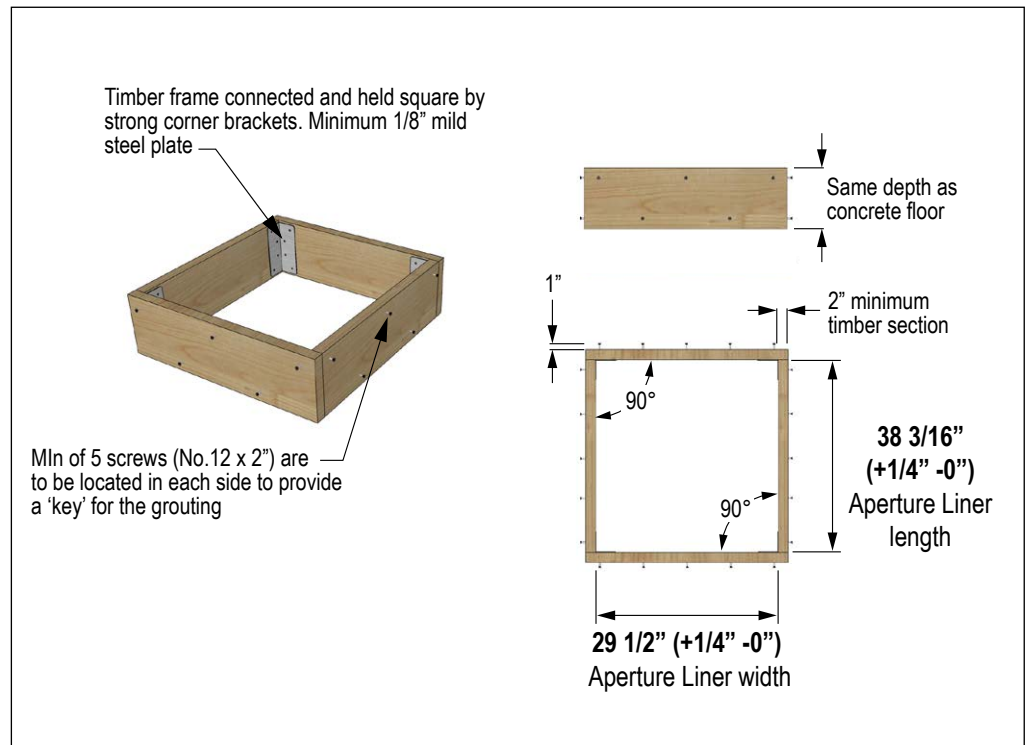

Upper Guide Ceiling Fix

Upper guides are either fixed through the ceiling or braced back to the wall - or in special cases, a combination of both.

In all cases, the ceiling fix and wall fix kit should be chosen at time of order, as they will not be packed with the lift unless they have been specified.

If the overall height of the guides exceed the actual height available then it will be necessary to reduce the length of the top guide on site. If the actual overall height available exceeds the overall height of the guides, then a top guide extension piece is required to extend the guides to the ceiling of the upper floor

It is essential that the ceiling kit is secured to ceiling joists of the upper floor that are capable of supporting the loadings detailed on the loading diagram (Page 10).

Within each kit are a ceiling plate and ceiling angle. Either one can be used, dependent on the layout of the joists. In all cases a minimum of 4 fixings must be used to secure to joists.

Ceiling Fix - Preferred method

Joists running perpendicular to wall

Used when the upper floor ceiling joists are running perpendicular to the wall against which the lift guides are positioned.

Fix Ceiling Cap to guides.

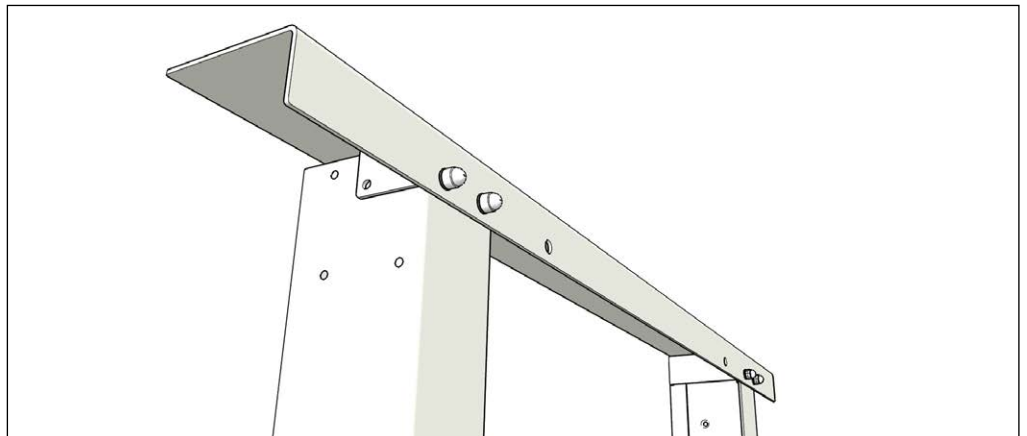

Fix Adjustable Ceiling Angle to cap.

M8 screws and nuts are used between the cap and the angle to provide adjustment.

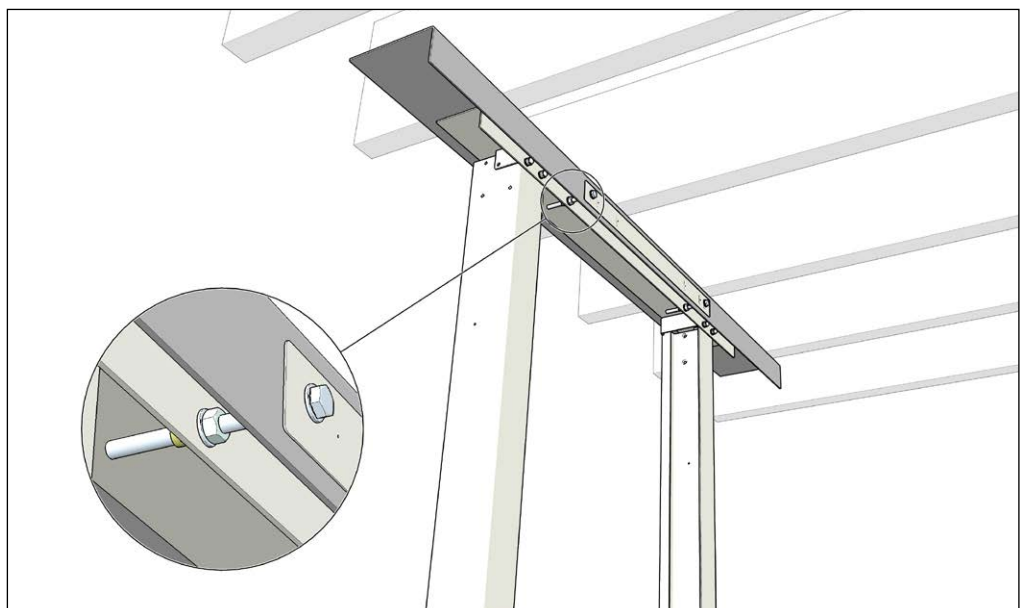

Joists running parallel to wall

Used when the upper floor ceiling joists are running parallel to the wall against which the lift guides are positioned.

Fix Adjustable Ceiling Plate to cap.

M8 screws and nuts are used between the cap and the plate to provide adjustment.

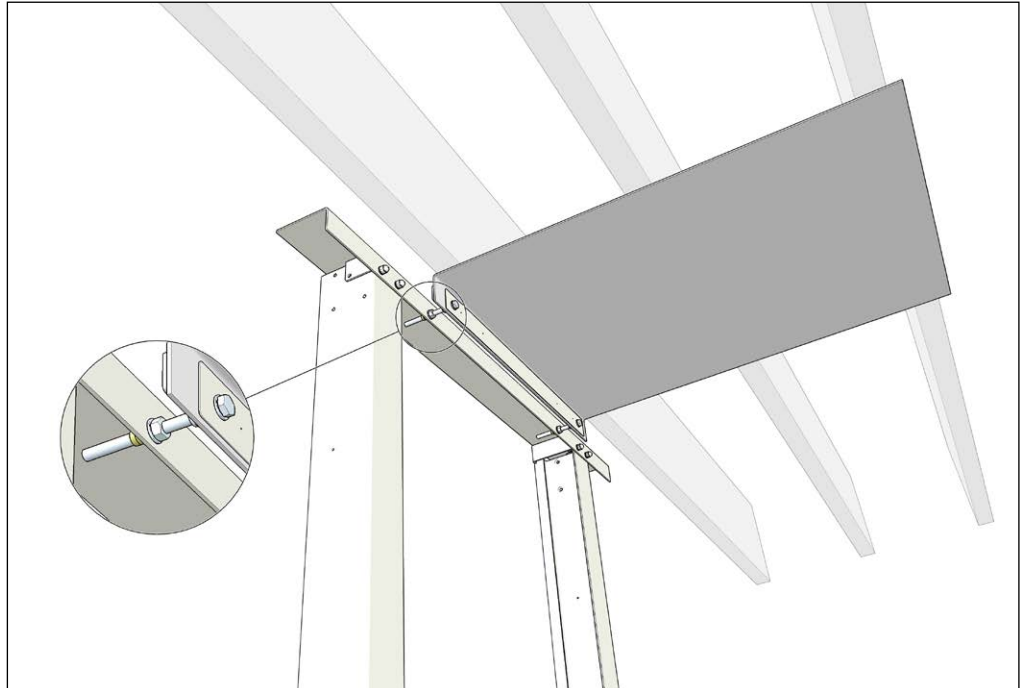

Wall Fix - Alternate method where ceiling fix is not possible

⚠ Note: If wall fixings are to be used and the gap between the back of the guides and the wall exceeds 4", please consult lift provider for structural requirements.

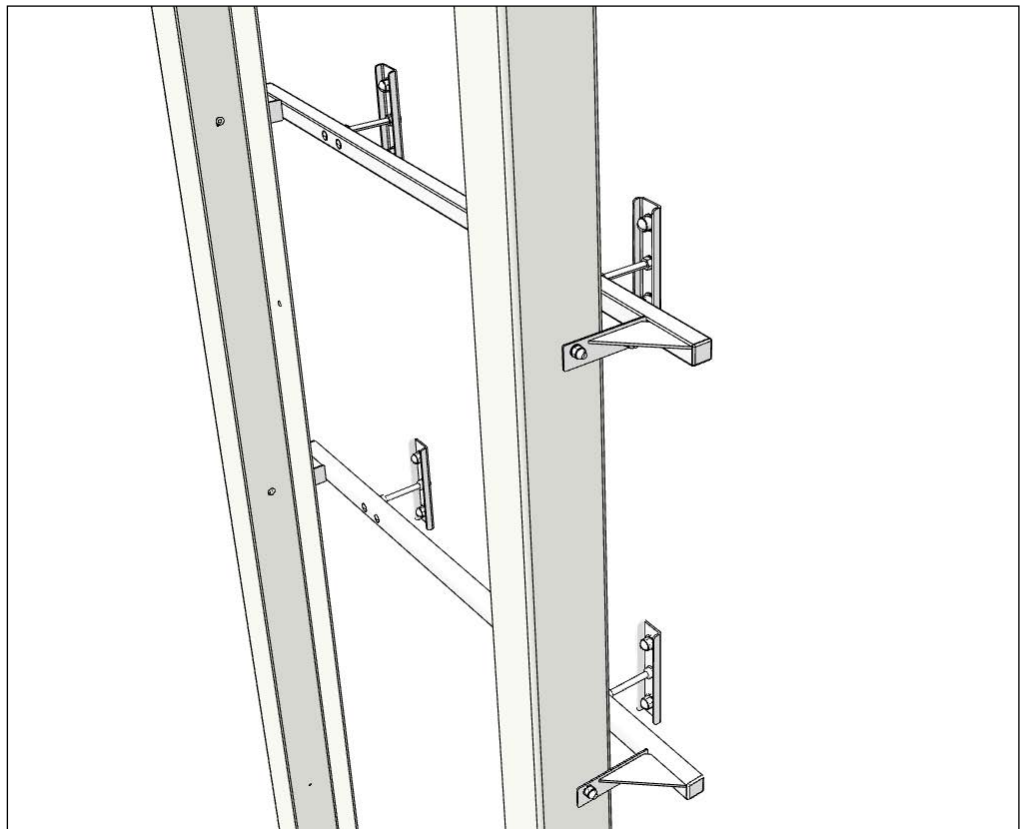

Intermediate Guides

- Lifts over 118" travel have intermediate guides to allow for differing ceiling heights within its range
- There will always be a guide join above and below the aperture
- Join below aperture needs to be braced back to wall, see Pages 18-19

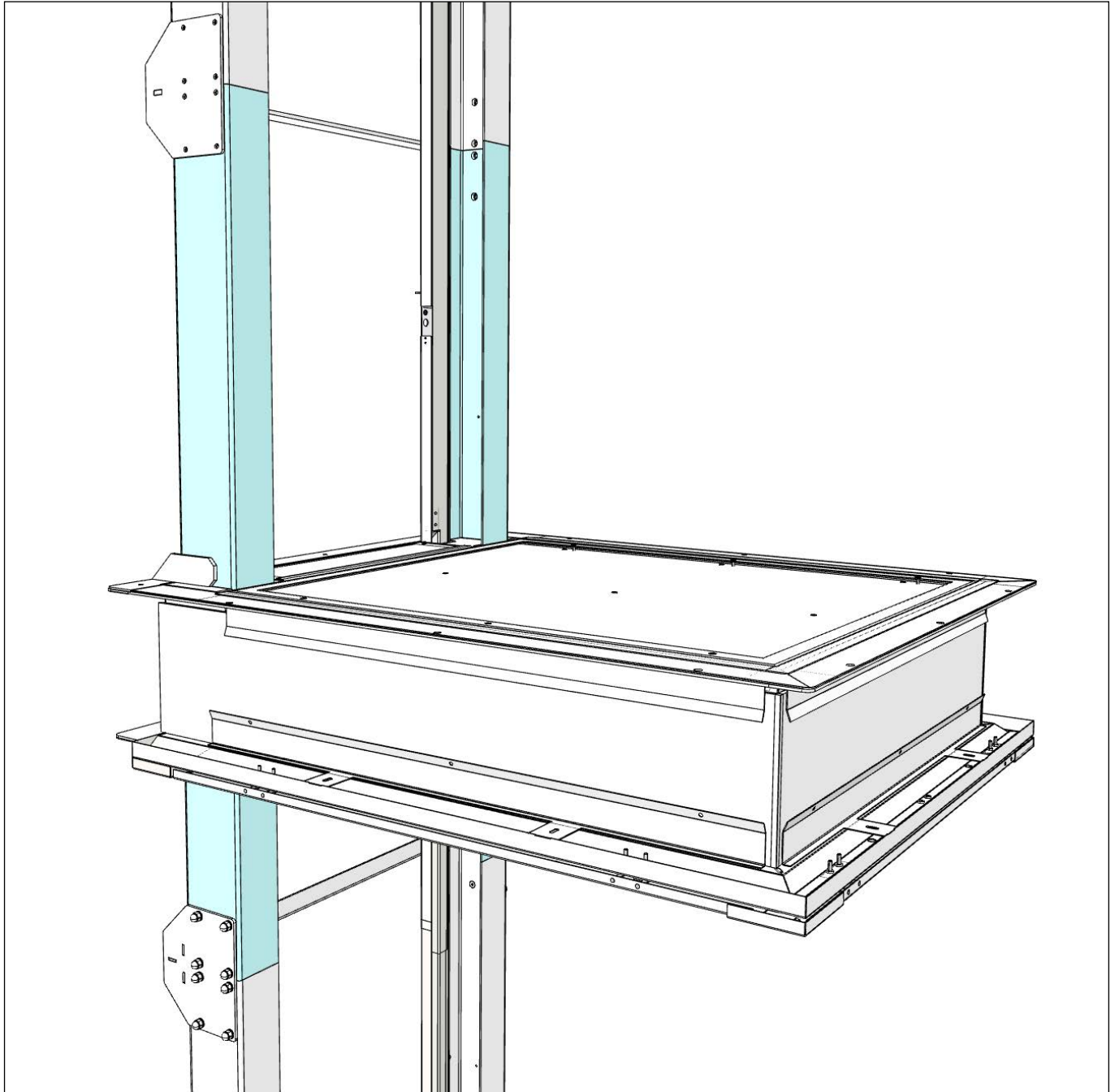

Downstairs Wall Patch (Subject to travel)

As part of the prep work it is necessary to fit a wall patch on the lower level wall to fix the crossbar brace to. The patch must be 3/4" WBP grade ply, painted white, and secured to the wall with minimum quantity of 6 x Ø1/4" coach screws.

The patch must be fitted to the dimensions below.

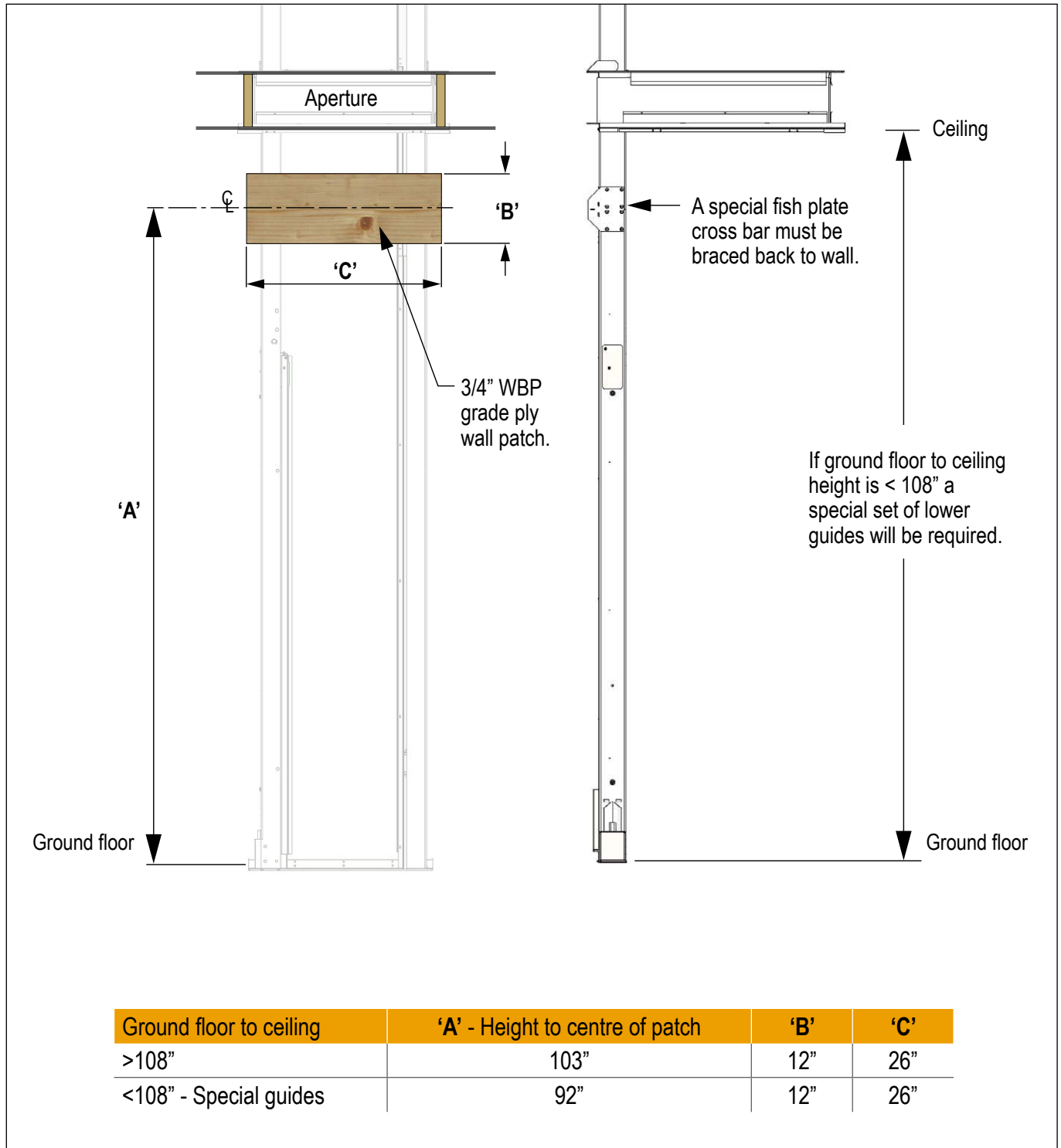

The lower guide brace kit can accommodate situations where the wall is up to 13 1/2" away from the rear of the aperture. If the distance is greater than this, a special bracing kit will be required.

Lower Guide Brace Kit

Normal circumstance

- 3 3/4" or less between rear of guides & wall patch
- Bracing Fish Cross Bar with Bracing Angle
- Slots allow for adjustment within this gap
- Use pilot holes to fix bracing angle in position

Special circumstance

- Gap greater than 3 3/4"
- Use Bracing Plate to bridge the gap and cut plate if necessary
- Use slots for adjustment
- Use pilot holes to fix in position

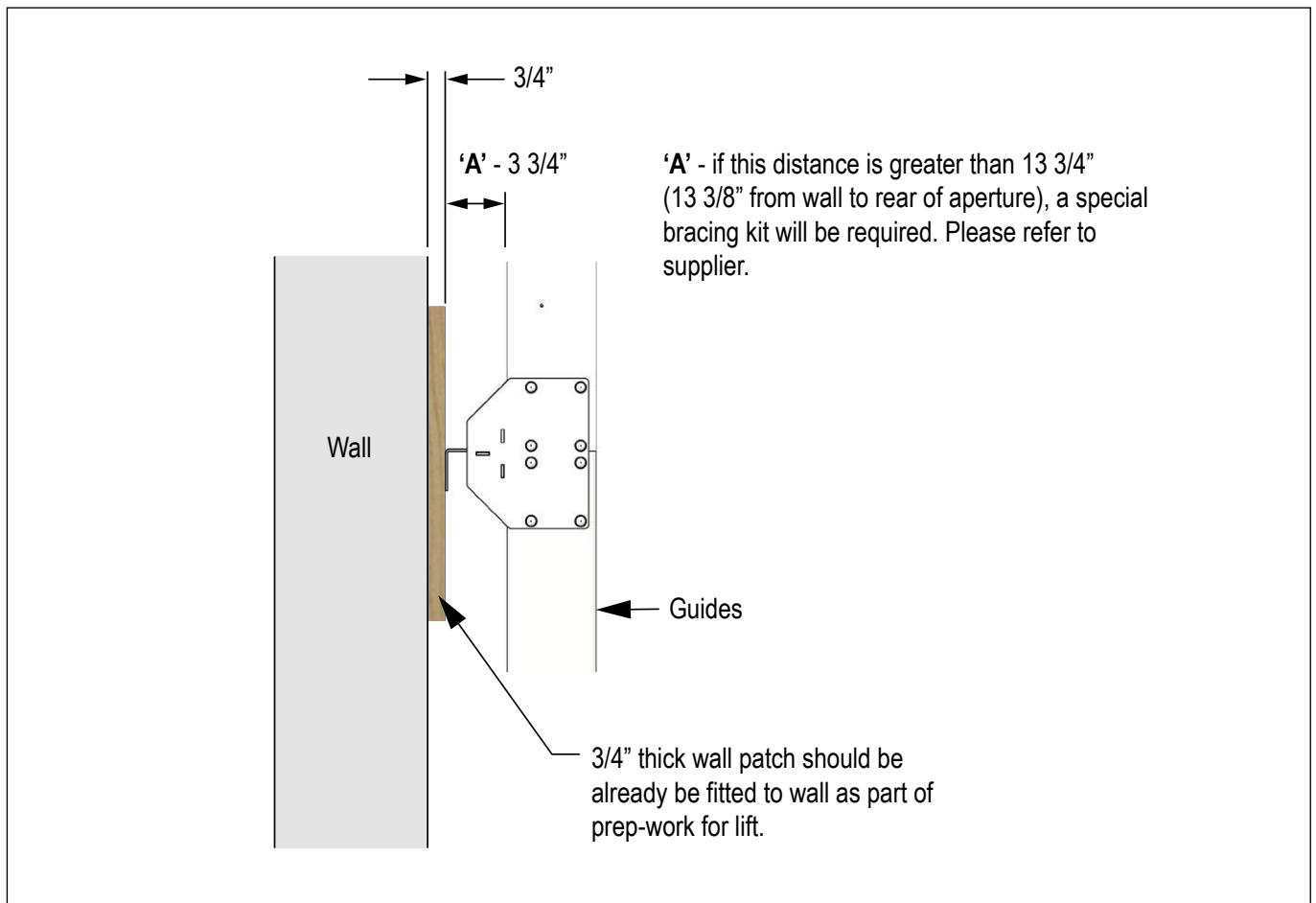

Skirting and Coving Considerations

⚠ Note: The inside face of the rear joist must be a minimum of 2" from the finished surface of the rear walls.

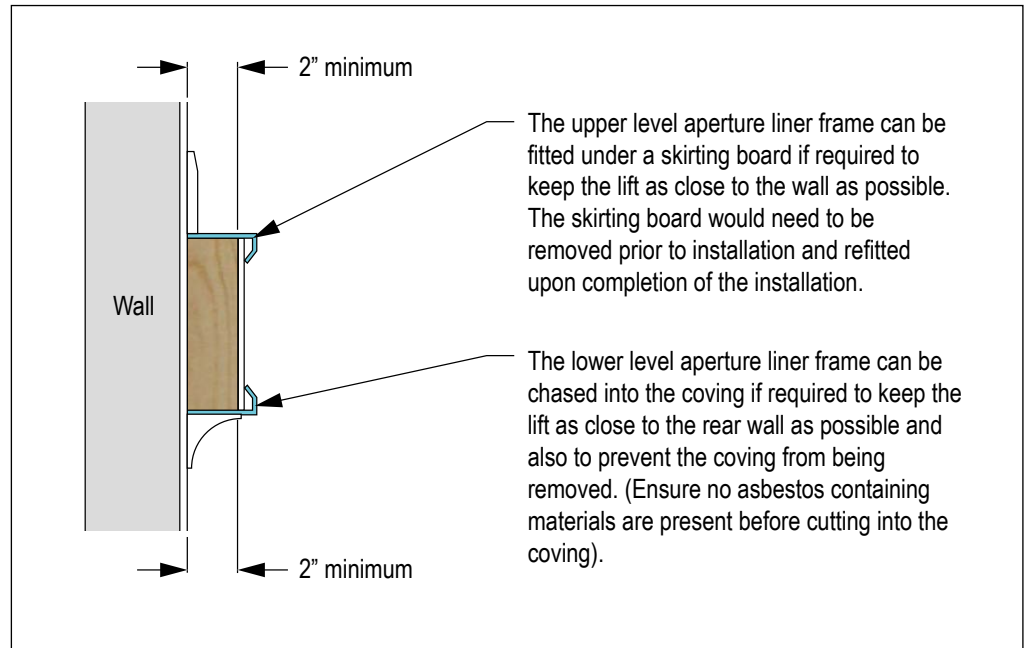

Infill

⚠ Note: If the gap between the rear of the guides and the wall exceeds 4", then an infill will be required.

In addition the following options could be employed at additional cost.

- False wall (by builder or other).
- Painted aluminium infill between guides (lift installer to fit).

The surveyor must always make their own risk assessment dependent on other occupants within the house and specify suitable protection.

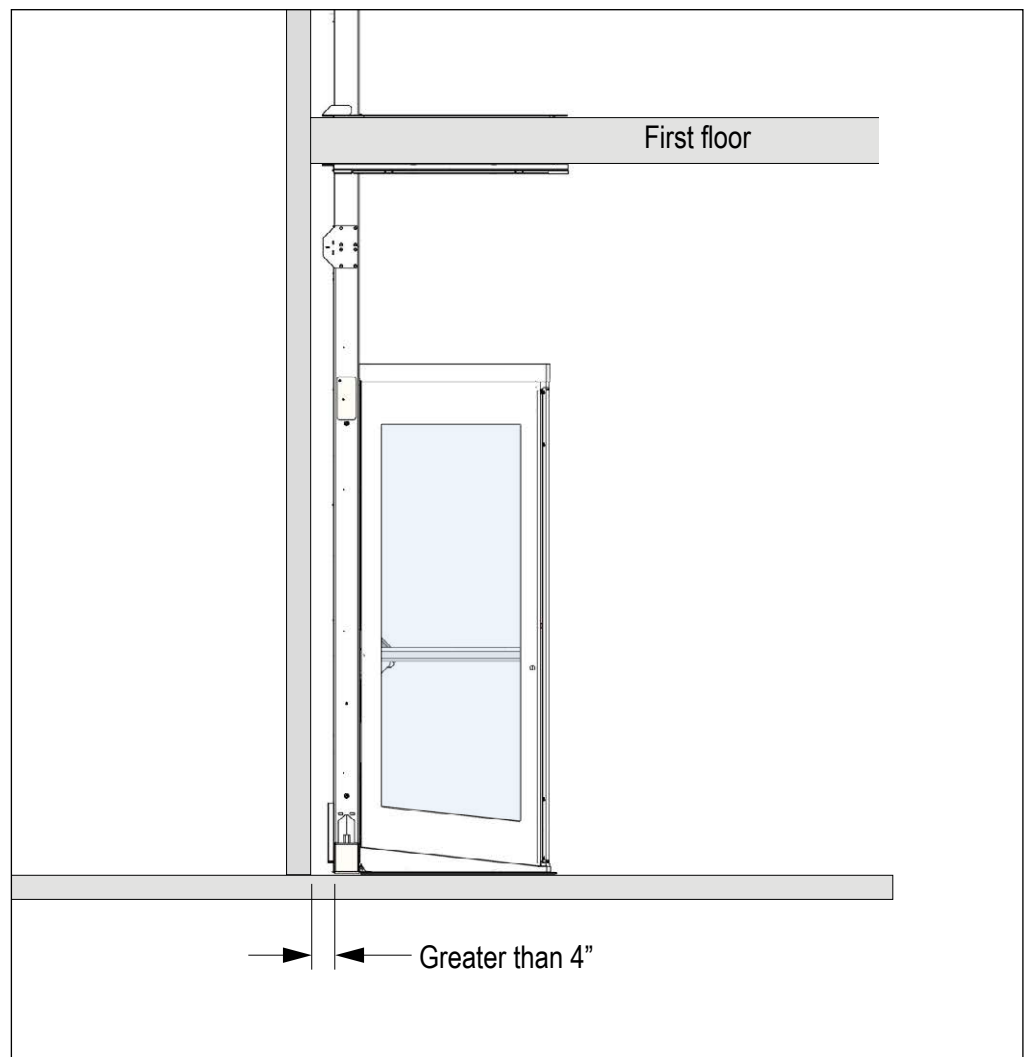

Control Details

Wall Mounted Call Station

Wireless Bluetooth control stations, consisting of Up, Down, Stop and Door controls are provided at each floor served.

The lights in the car will switch on automatically when any call button is pressed and will automatically turn off after a few minutes. (Time delay adjustable on call station controls).

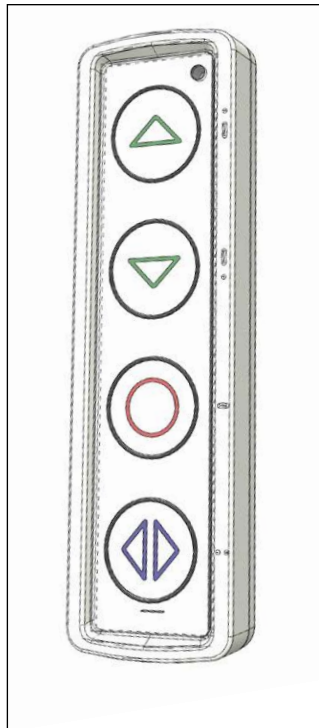

Flush Mounted Call Station

Optional flush mounted panel for solid or plasterboard walls.

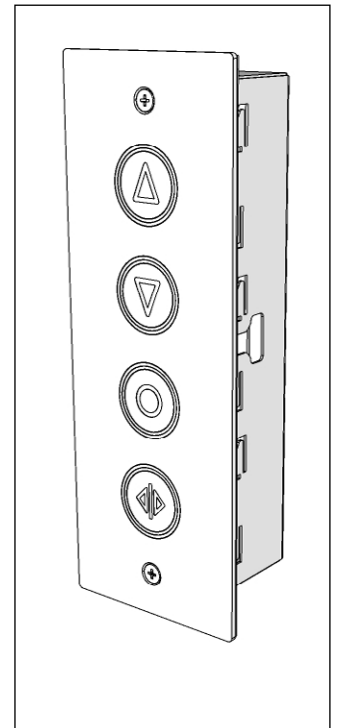

Car Controls

Consisting of Up, Down, Stop and Door controls.

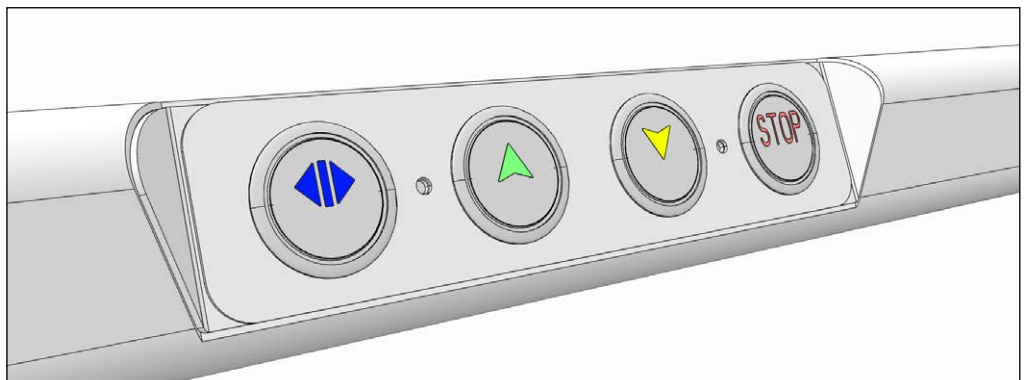

Remote Isolate Fob

The lift can be isolated by using the optional remote control fob. When the lift is 'isolated', none of the control stations will function. The control stations can only be activated by using the remote fob. When the lift is activated, the coloured indicator lights in the car will illuminate.



Brick / Solid Wall

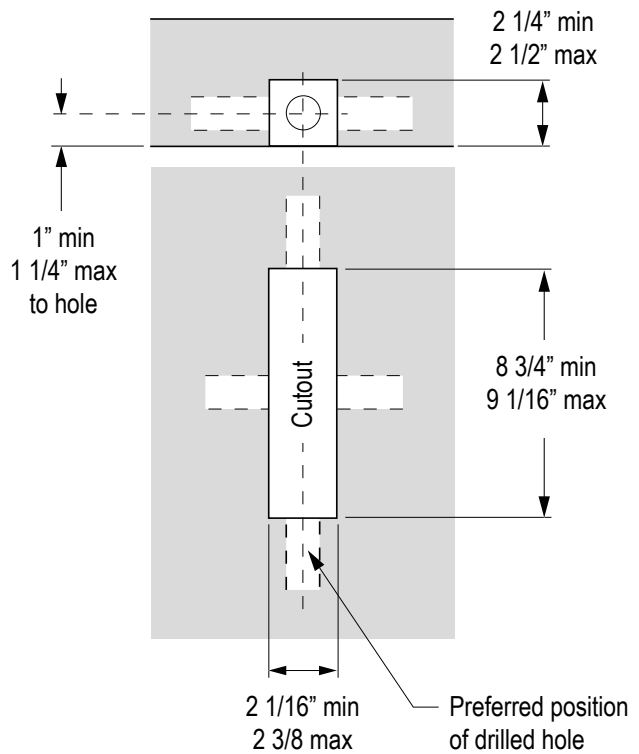
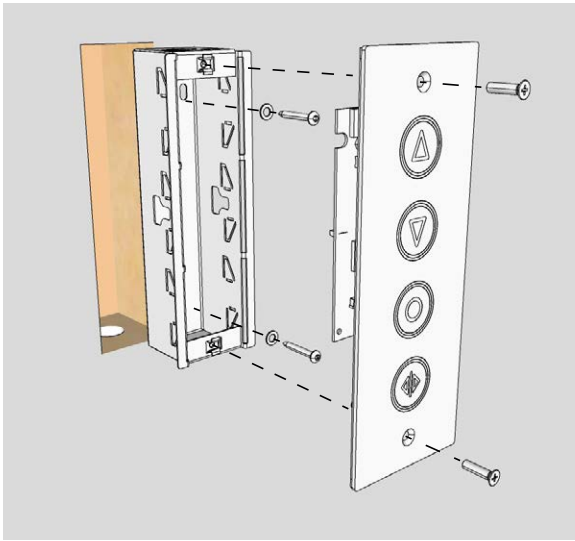

⚠ Note: A $\text{Ø}3/4$ " min by 5" min deep hole must be drilled in one of four directions into the brick and as close as parallel to the wall surface as drill will allow. Antenna must fit into hole. Select direction of hole based on individual site conditions.

Plasterboard Wall

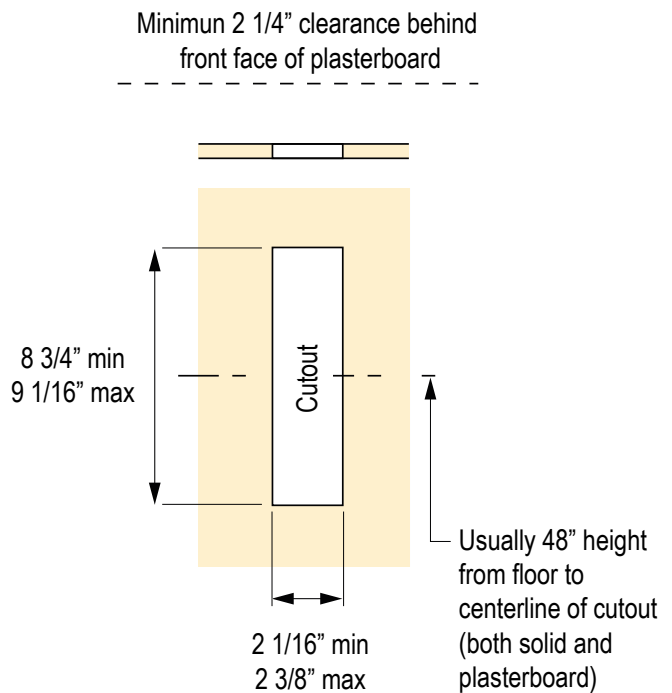
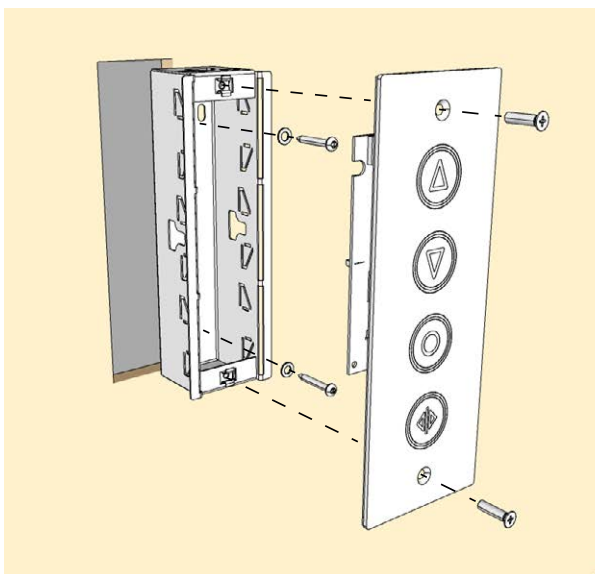

Spec Check List

Details specific to lift _____

- Page 02 Specification
- Page 04 Site Considerations
- Page 06 Electrical Schematic
- Page 08 Minimum Headroom Requirements
- Page 10 Loading Details
- Page 11 Aperture in Floor Joists
- Page 12 Example Double Joists
- Page 13 Upper Level Finish Floor
- Page 13 Aperture Protection
- Page 14 Installation in Concrete Floor
- Page 15 Upper Guide Ceiling / Wall Fix
- Page 16 Wall Fix - Alternate method where ceiling fix is not possible
- Page 17 Intermediate Guides
- Page 18 Downstairs Wall Patch
- Page 19 Lower Guide Brace Kit
- Page 20 Skirting and Coving Considerations
- Page 21 Control Details
- Page 22 Flush Mounted Control
- Page 25 Site Check Form



Note: Please ensure Site Check List XE00027 is completed and returned to Terry Group Ltd.
at installations@terrylifts.co.uk

Affinity Site Check Form - XE00027

Affinity Site Check Form - Refer to the relevant specification guide for detail

Customer Information

| | |
|---------------------|--|
| Lift reference | <input type="text"/> |
| Customer name | <input type="text"/> |
| Address/Location | <input type="text"/> Zip Code <input type="text"/> |
| Site contact number | <input type="text"/> |

| Lift Area | | Yes | No | N/A |
|-----------|---|----------------------------|--|--|
| Checks | | | | |
| a | Internal length of aperture: <input type="text"/> (" | | | |
| b | Internal width of aperture: <input type="text"/> (" | | | |
| c | Diagonals of aperture <input type="text"/> (" x <input type="text"/> (" | | | |
| d | The internal face of the joists on the rear and on both sides must be a minimum of 2" from finished walls/skirting boards/coving. | Lower level Upper level | <input type="checkbox"/> <input type="checkbox"/> | <input type="checkbox"/> <input type="checkbox"/> |
| e | Are guide rear infills required? (Required when aperture is greater than 4" from the back wall) | Lower level Upper level | <input type="checkbox"/> <input type="checkbox"/> | <input type="checkbox"/> <input type="checkbox"/> |
| f | Joist configuration as per specification guide? | | <input type="checkbox"/> | |
| g | 4 x visible joist hangers? | | <input type="checkbox"/> | |
| h | Underside of all joists covered with plasterboard and skim? | | <input type="checkbox"/> | |
| i | Joists are plumb? | | <input type="checkbox"/> | |
| j | Building works approved by building control? | | <input type="checkbox"/> | |
| k | Upper floor is level around aperture (max 1/4" in all planes) | | <input type="checkbox"/> | |
| l | Finish floors in place at both landings (if not then a sample is required) | | <input type="checkbox"/> | |
| m | Lower level floor structurally sound? | | <input type="checkbox"/> | |
| n | Distance from the end of the aperture to any walls must be a minimum of 47" at each landing. Lower <input type="text"/> (" Upper <input type="text"/> (" | | <input type="checkbox"/> | |
| o | Ground floor to ceiling dimension <input type="text"/> (" | | | |
| p | Aperture depth (floor thickness): <input type="text"/> (" | | | |
| q | Upper floor to ceiling dimension (including floor covering): <input type="text"/> (" | | | |
| r | Is there any under floor heating at either landing? | | <input type="checkbox"/> | |
| s | Any confirmed asbestos? | | <input type="checkbox"/> | |
| t | All areas around the lift are decorated / finished? | | <input type="checkbox"/> | |

Affinity Lift Site Check Form - Refer to the relevant specification guide for detail

| Electrical | | Yes | No |
|---------------|--|--------------------------|--------------------------|
| Checks | | | |
| a | Dedicated power supply installed and live at lower level adjacent to power pack position? | <input type="checkbox"/> | <input type="checkbox"/> |
| b | Dedicated analogue phone line installed and live at lower level adjacent to power pack position? (Only applicable on HFE and Lifestyle and when specified on a Harmony) | <input type="checkbox"/> | <input type="checkbox"/> |
| c | Can the power supply be accessed when the lift is parked at the lower landing? | <input type="checkbox"/> | <input type="checkbox"/> |
| d | Any agreed sockets have been blanked off? | <input type="checkbox"/> | <input type="checkbox"/> |

| Pre Install Criteria - Note: All lifts are delivered in an extra-long wheel base transit van | | Yes | No |
|--|---|--------------------------|--------------------------|
| Checks | | | |
| a | Is there suitable offloading access adjacent to the building? | <input type="checkbox"/> | <input type="checkbox"/> |
| b | Is there suitable access for the transportation of the lift through the building to the lift area? | <input type="checkbox"/> | <input type="checkbox"/> |
| c | Is a trolley required? | <input type="checkbox"/> | <input type="checkbox"/> |
| d | Is there available parking for large transit vans close to the site? If not, what parking is available and where? <input type="text"/> | <input type="checkbox"/> | <input type="checkbox"/> |
| e | Is the site area clean? | <input type="checkbox"/> | <input type="checkbox"/> |
| f | Is a site induction required? | <input type="checkbox"/> | <input type="checkbox"/> |
| g | Are there welfare facilities available on site? | <input type="checkbox"/> | <input type="checkbox"/> |
| h | Site working hours if applicable? (hh:mm) Start: <input type="text"/> Finish <input type="text"/> | | |

Additional comments

| Required photographs | | Yes | No |
|----------------------|---|--------------------------|--------------------------|
| 1 | Exposed aperture from above and below. | <input type="checkbox"/> | <input type="checkbox"/> |
| 2 | Level across aperture in all 4 planes. | <input type="checkbox"/> | <input type="checkbox"/> |
| 3 | Power supply and phone point position. | <input type="checkbox"/> | <input type="checkbox"/> |
| 4 | Aperture covered with 3/4" WPB ply. | <input type="checkbox"/> | <input type="checkbox"/> |
| 5 | Lift area from a distance at both landings. | <input type="checkbox"/> | <input type="checkbox"/> |

Engineer

Name: Date:

Signature:

Please send this document and supporting photographs to installations@terrylifts.co.uk. For any queries, please call +44 (0)1565 752 800 (option 5) - Technical Support

Terry Lifts

Terry Group Ltd.

1 Longridge Trading Estate
Knutsford, Cheshire, WA16 8PR

01565 752 800

sales@terrylifts.co.uk

www.terrylifts.co.uk



Proudly Designed and Manufactured in Britain

ED35502