

AmeriGlide Affinity Elevator Approval Drawings

DIMENSIONS

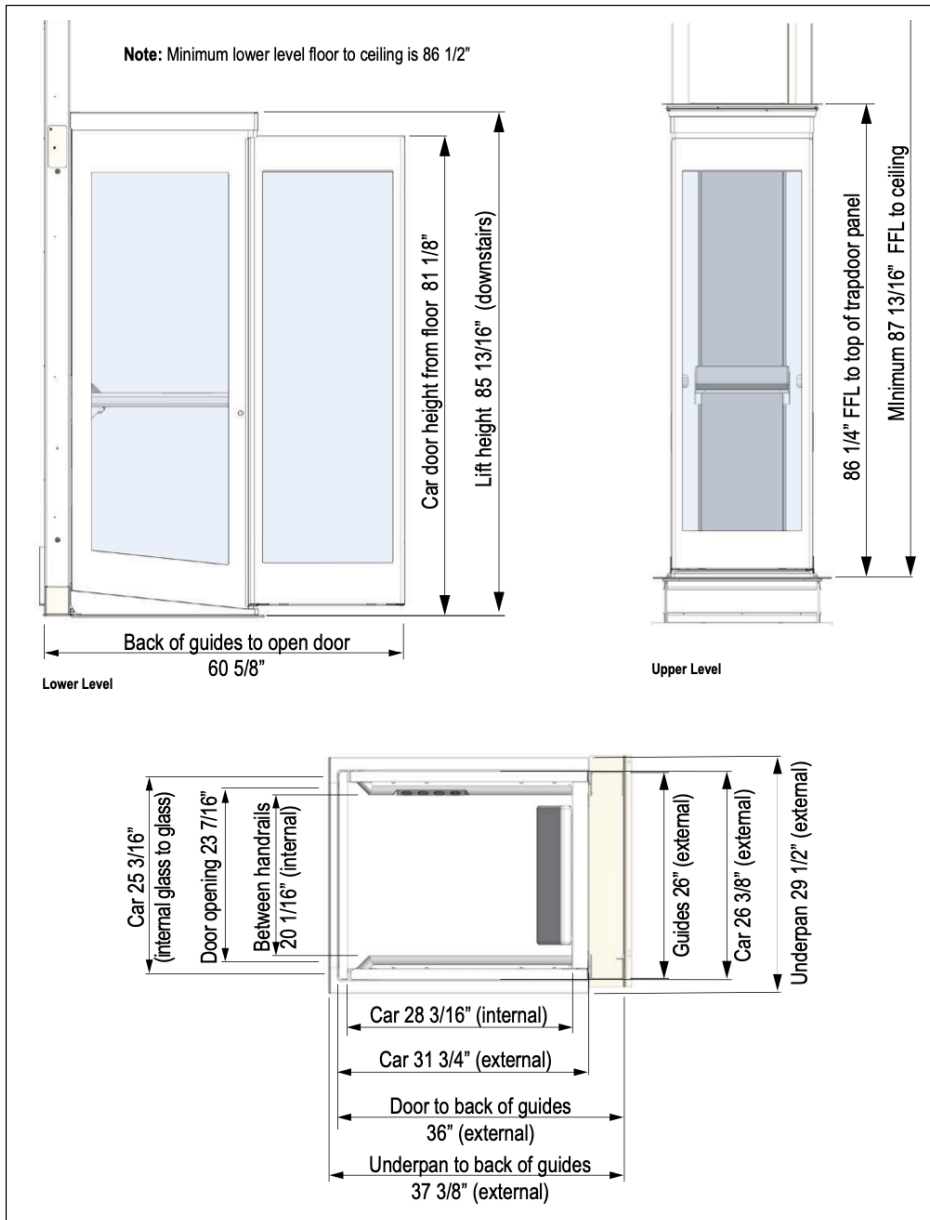

Standard Capacities / Travel

Capacity:

Carriage - 550 lbs. (250 kg)
Trapdoor - 550 lbs. (250 kg)

Note: Maximum floor covering weight which can be applied to trapdoor 14 lb. (6.35 kg) evenly distributed.

Travel:

141"

Speed:

11.88 fpm

MINIMUM HEADROOM REQUIREMENTS

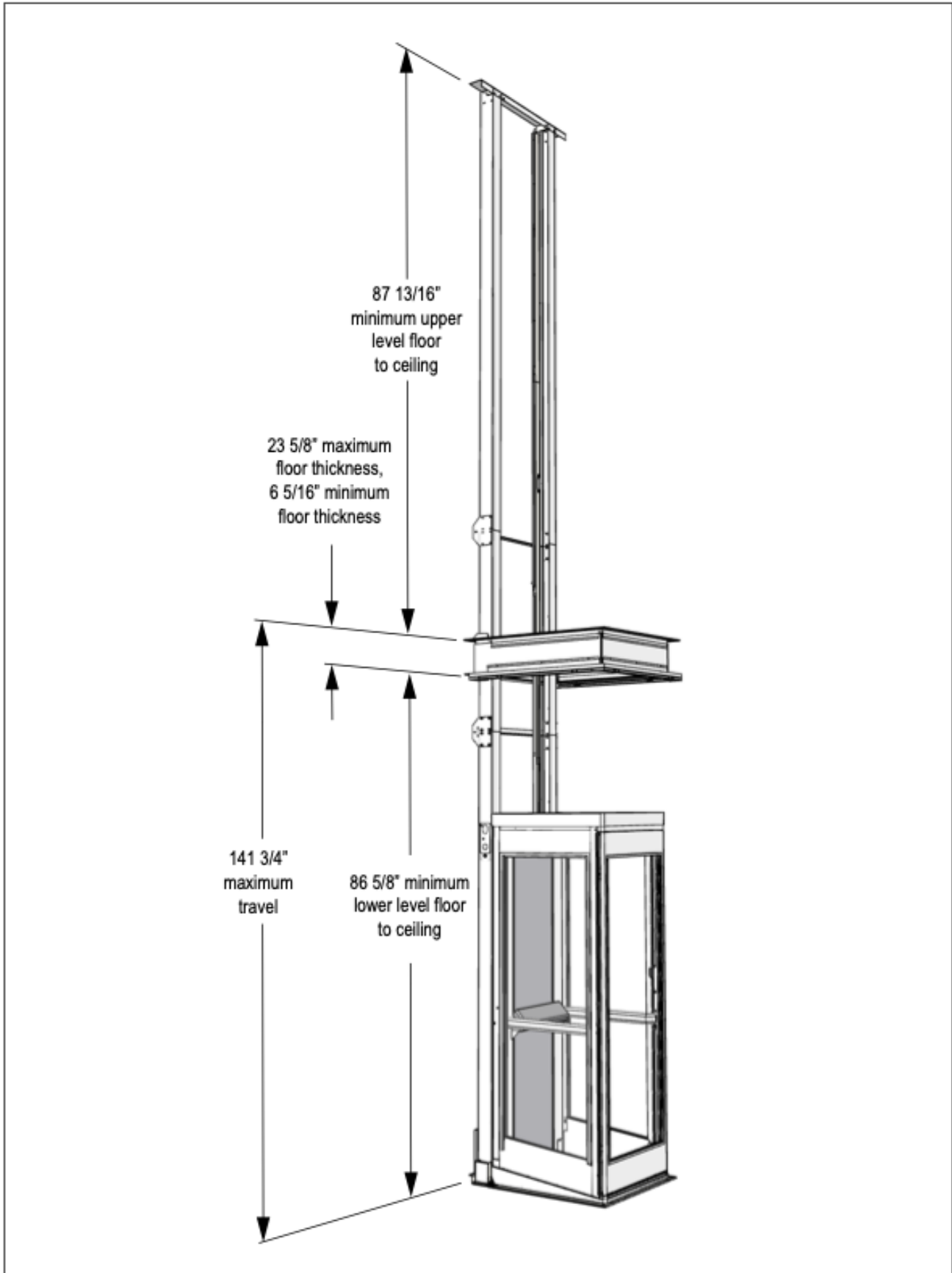

GUIDES

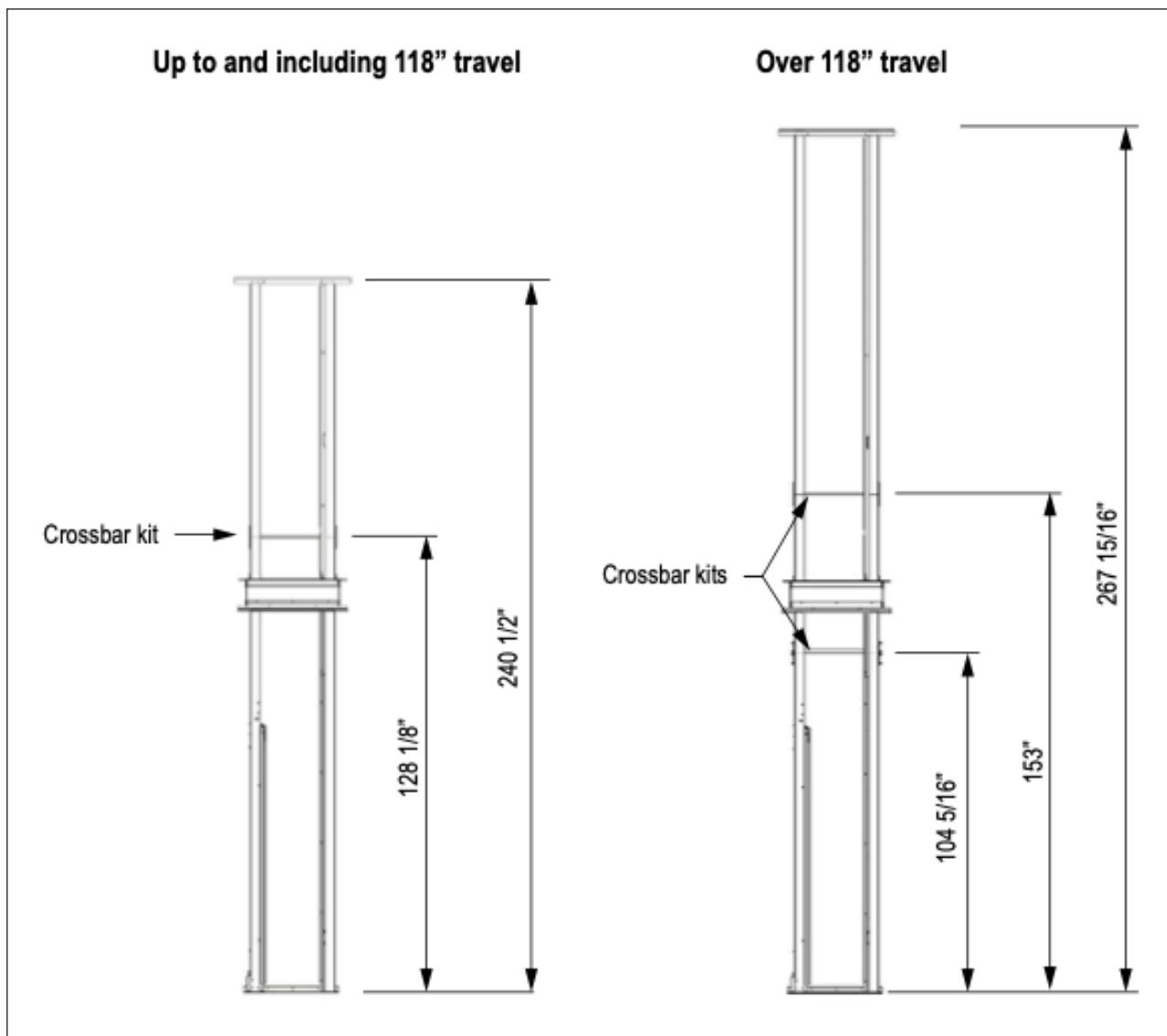

NOTE

- If the lower level floor to ceiling is less than 84 5/8" then special guides will be required.
- If the actual overall height available exceeds the overall height of the guides (240 1/2") then a top guide extension piece (30" long) is required to extend the guides to the ceiling of the upper floor.

NOTE

- If the lower level floor to ceiling is less than 110" then special guides will be required.
- If the actual overall height available exceeds the overall height of the guides (265") then a top guide extension piece (30" long) is required to extend the guides to the ceiling of the upper floor.

LOADING DETAILS

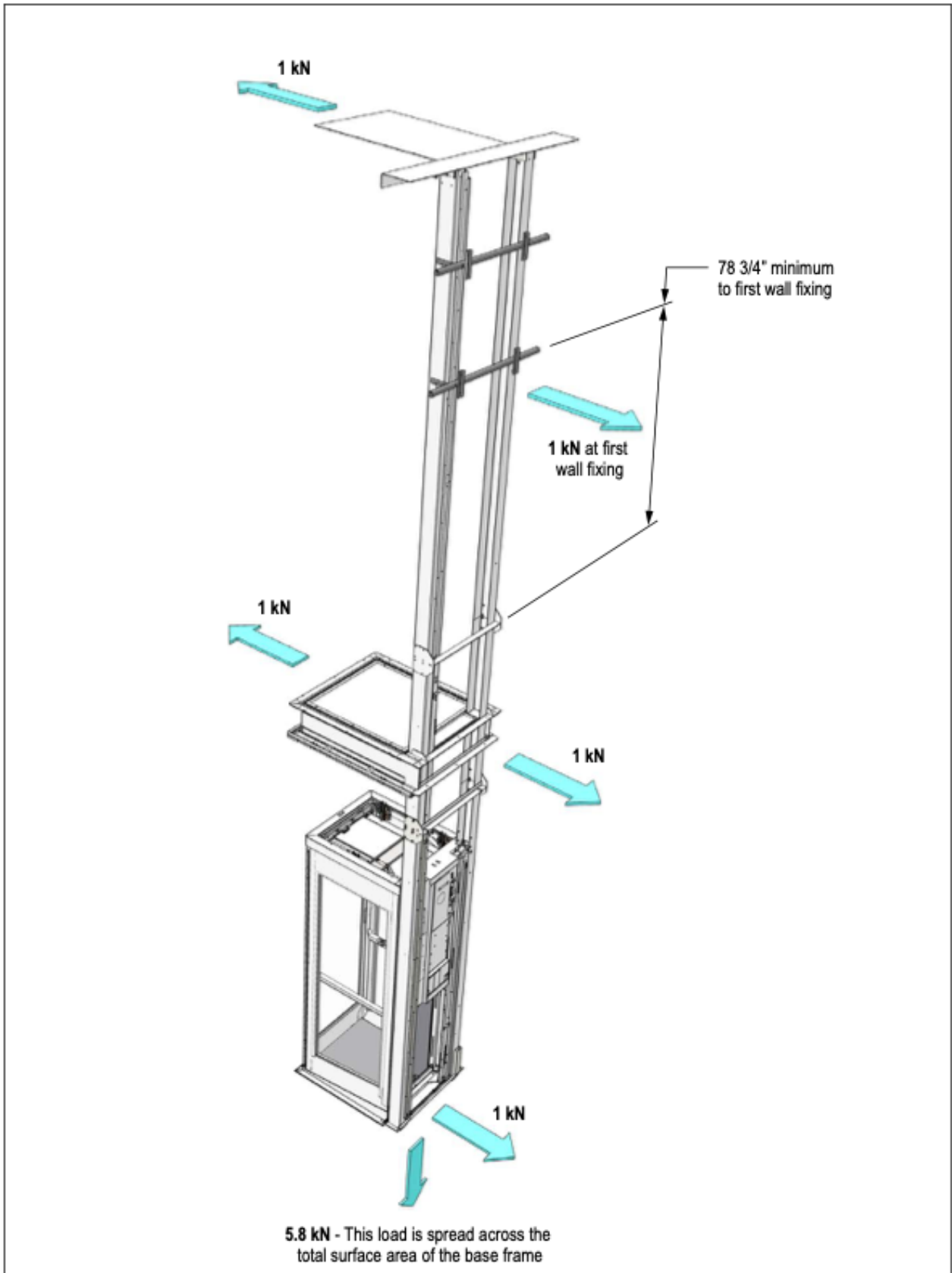

APERATURE DETAILS

Aperture in Floor Joists

NOTE: Ensure the upper floor is levelled perfectly. It is essential the aperture be formed level. Any deviation of aperture level will result in the aperture needing to be re-levelled.

- The rear wall joist must be installed at all times. It provides the main load bearing attachment support for the aperture.
- All joists to be fitted perfectly level in all planes. The top surface of the joists must be perfectly level and square.
- Minimum floor thickness is $6 \frac{5}{16}$ " and maximum $23 \frac{5}{8}$ ". Please specify a 'Deep Aperture ($13 \frac{13}{16}$ " - $23 \frac{5}{8}$ ")' where the aperture depth exceeds $13 \frac{13}{16}$ ".
- Joist ends should be trimmed onto other joist using proprietary joist hangers or built into structural walls by a min 4".
- To comply with Building Regulations all supporting and trimming joists will be double joists.

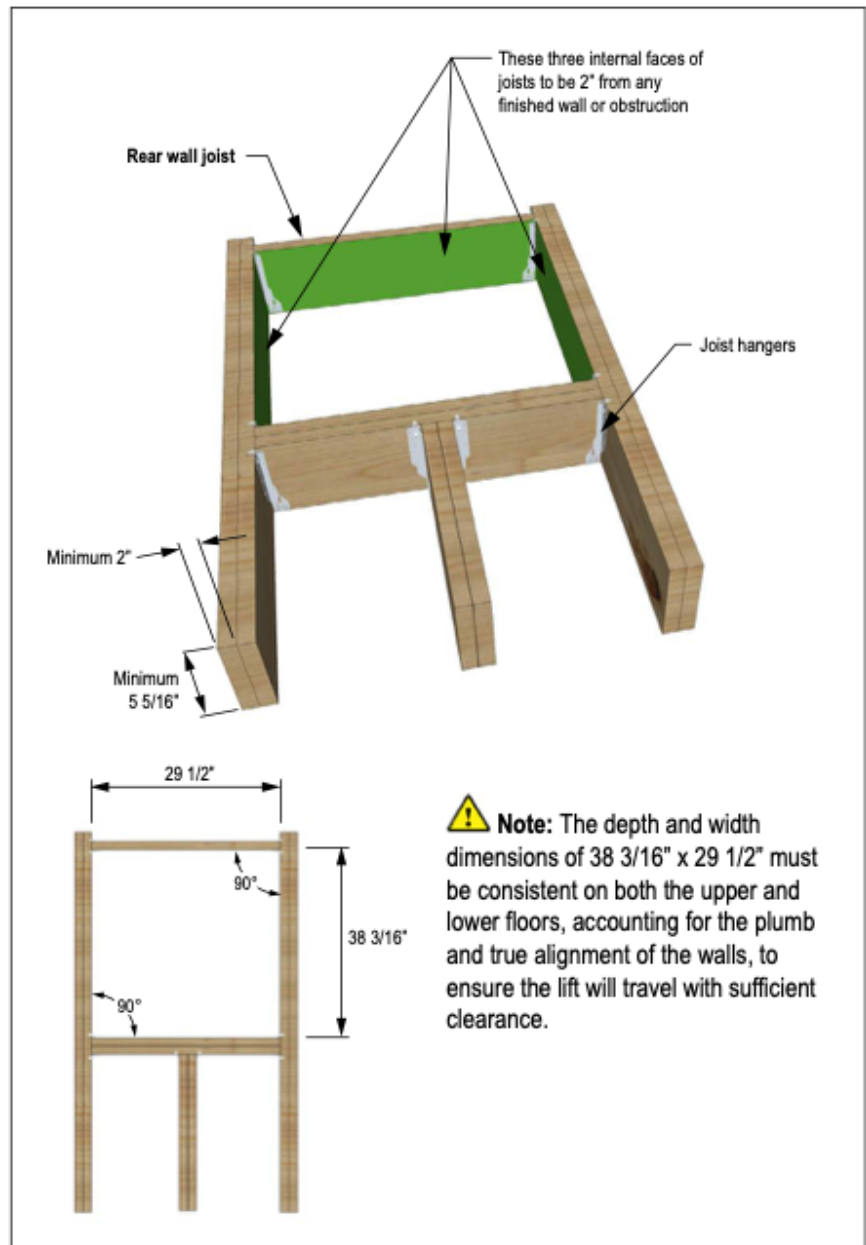

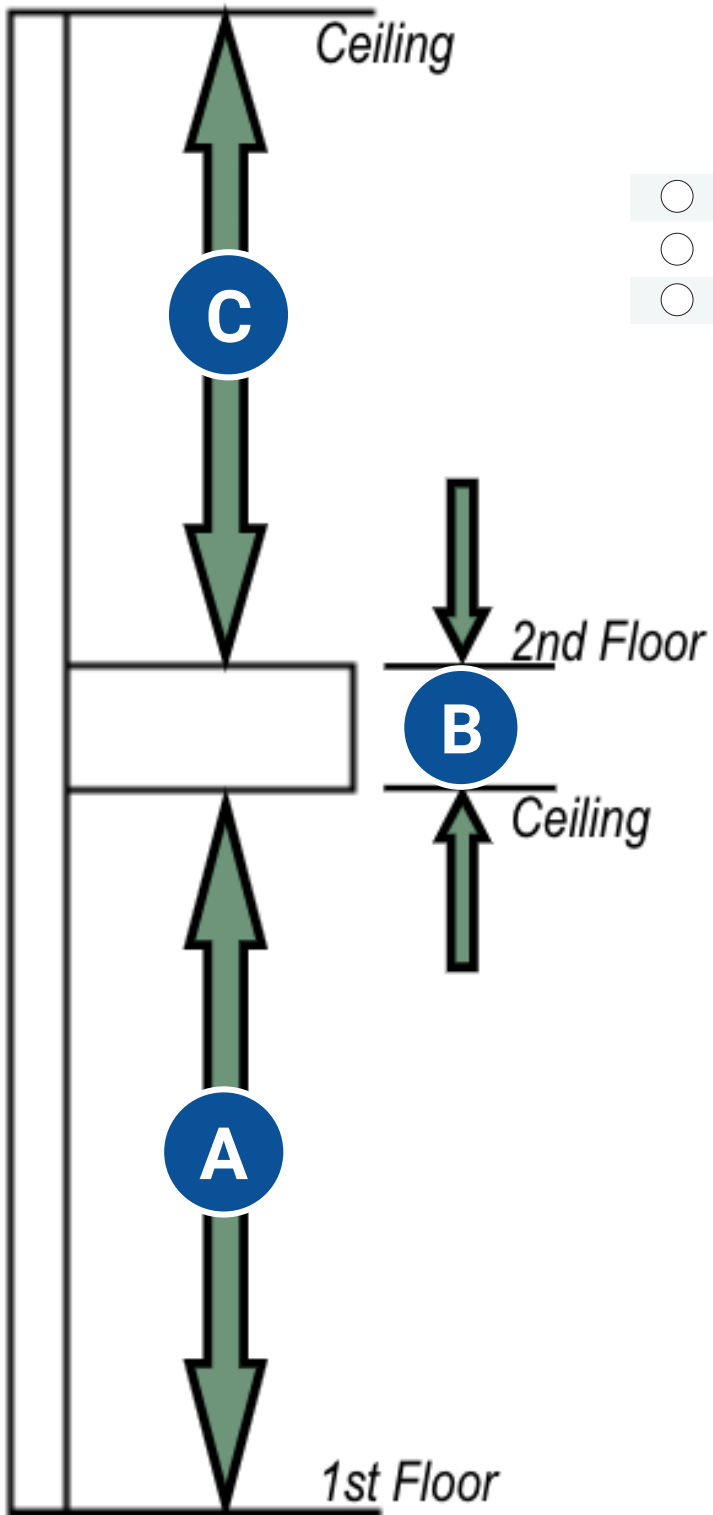

2nd Floor to Ceiling: _____

Ceiling to 2nd Floor: _____

1st Floor to Ceiling: _____

AmeriGlide Terms and Conditions

Acceptance

The contract shall consist only of our offer and your acceptance of the Order Form and these terms, nothing else shall form part of the contract and be binding on either you or us. It is our responsibility to supply you with goods that meet your consumer rights. Nothing in this contract affects your statutory rights. By accepting you acknowledge and agree to have read, understood and agreed to be legally bound to the terms and conditions set out below. Unless otherwise stated, you agree to pay as follows:
100% payment upon signed acceptance.

Payment

- Payment to be made by check or ACH bank transfer only unless otherwise noted.
- If credit card payment is requested and accepted a 3% service charge will be added to the invoice.
- Overdue Invoice: A service charge of 18% annually shall apply to overdue accounts past thirty (30) days.
- If you do not pay within sixty (60) days from the billing date we may choose to do one of the following:
1) suspend all work until the amount has been paid, or 2) declare all sums for the unexpired term of this agreement due immediately and terminate this agreement. This will void warranty and technical support.

Cancellation Charges

The following are charges that will be applicable during the production process of items purchased.

25% of purchase value	Completion of engineering drawings
50% of purchase value	Once equipment enters production
80% of purchase value	Once production is 50% complete
100% of purchase value	Once production is 100% complete

Note: that once production of purchased equipment has been completed, the product is non refundable. Products are custom built and cannot be returned once completed.

Specific Terms and Conditions

1. Responsibility of Purchaser

- a. Purchaser is responsible for checking the product for damages upon its arrival. Once delivery has been accepted, the purchaser accepts responsibility for the condition of the product.
- b. Purchaser is responsible for unloading delivery. Delivery to a job site requires the customer to have a forklift available, or it must be picked up at a local terminal. In some cases, not all customers can purchase forklift delivery.

2. Terms and Conditions of Sale

- a. In consideration of AmeriGlide Distributing 2019 performing the services herein specified, you expressly agree to indemnify, defend, save harmless, discharge, release and forever acquit AmeriGlide Distributing 2019, our officers, our employees from and against any and all claims, demands, suits, and proceedings brought against us or our employees of any nature whatsoever, including but not limited to loss, damage, injury or death that are alleged to have arisen from or alleged to be in connection with misuse, maintenance, operation or condition of the equipment covered by this agreement.
- b. Typical lead time for delivery can vary based on product.
- c. Production lead time begins upon receipt of signed approval drawings and execution of contract terms.
- d. Change orders must be communicated with a signed change order request document approved by both parties and may be subject to additional cost(s).
- e. **Storage fees:** Equipment may be stored for up to 10 business days after the requested equipment delivery date at no charge. Additional storage is available at \$50/day.
- f. Quotes are valid for 7 business days from the date of issue, quotes older than 7 business days may be subject to repricing.
- g. Installation must be completed within 1 year of contract acceptance or price increase may result.
- h. **Attorney Fees.** In the event that there is any controversy or claim arising out of or relating to this Agreement, or to the interpretation, breach or enforcement thereof, and any action or proceeding is commenced to enforce the provisions of this Agreement, the prevailing party shall be entitled to a reasonable attorney's fee, costs and expenses.
- i. Any overdue invoice past 60 days will void the warranty. Interest will be applied.
- j. We reserve the right to deny turn-over of equipment until the complete payment has been received.
- k. Warranty is valid for two (2) years on all parts from the date of shipping.
- l. Installation must be completed by a trained licensed professional. Failure to have a trained licensed professional may result in voiding all warranties.
- m. All home modifications and construction are the responsibility of the purchaser. Ameriglide does not perform any home modifications, construction, or electrical work required for the lift installation.
- n. I also acknowledge that, as the purchaser, it is my responsibility to ensure compliance with all state and federal permits and regulations.
- o. Any **third party installation** (Installation completed by anyone other than an AmeriGlide Distributing 2019 or their agent and paid separately from this contract) comes with a one hour of free technical service. Each call will be counted as a minimum 15 min call. All technical service calls after the included hour will be billed at \$200 per hour with a minimum call / charge of \$50.00 for 15 mins. This does not include the initial hold time and must be paid in advance on a valid credit card. All technical service call fee's are non refundable.
- p. Any **third party installation** (as indicated above) revokes any right to sue for component breakage, injury related to use, or damage related to other third parties in the form of prejudice or delays in the face of malfunctions of the product or improper installation by that third party.
- q. **Ownership Clause:** Until the product is fully paid, the product shall remain the property of AmeriGlide Distributing 2019 ("AmeriGlide"). In the event that the full payment is not received in accordance with the agreed terms, AmeriGlide reserves the right to retake possession of the product without further notice. The customer acknowledges and agrees that AmeriGlide has a security interest in the product until full payment is received.

- By checking this box, the purchaser acknowledges that Ameriglide will be responsible solely for providing the product and warranty of parts. Installation will be the responsibility of the purchaser and will be performed independently of Ameriglide. Ameriglide assumes no responsibility for any work performed by the installer.
- Ameriglide offers installation support. Upon request, Ameriglide will assist with installation for a fee. By checking this box, the purchaser acknowledges and agrees to waive the option for installation assistance.

By signing this agreement, the customer agrees to drawings detailed in previous pages and acknowledges and agrees to the above mentioned terms.

Shipping Information:	Type of Delivery:
Contact _____	<input type="radio"/> Pick-up at Terminal
Phone _____	<input type="radio"/> Loading Dock
Address _____	<input type="radio"/> Onsite Forklift
City _____	<input type="radio"/> Flatbed and Forklift
Province / State _____	
Postal Code / ZIP _____	
Purchaser Signature: _____	Date: _____
Printed Name: _____	Title: _____

